

LED Solutions

High Brightness LEDs

- 2 High Brightness Through-hole Lamps
- 12 Surface Mount PLCC LEDs
- 24 Envisium™ Surface Mount Power PLCC-4 LEDs
- 28 Moonstone™ High Power LEDs
- 36 High Power LEDs

LED Indicators and Displays

- 40 Standard Through-hole Lamps
- 45 Subminiature Lamps
- 49 Surface Mount ChipLEDs
- 57 Auto Focus Auxiliary Flash LEDs
- 59 Seven-Segment Displays
- 88 Light Bars and Bar Graph Arrays
- 92 Smart Displays



LED Solutions

Avago Technologies is one of the largest producers of visible light-emitting diodes in the world.

Avago Technologies offers “one-stop shopping” with its wide array of LED (Light Emitting Diodes) Solutions. With our large manufacturing base and many years of experience from our HP and Agilent days, we are one of the largest producers of visible LEDs in the world and ships billions of products annually.

Avago employs the latest in material and process technology to produce superior LEDs. Our highly acclaimed AlInGaP (aluminium indium gallium phosphide) LED material offers high brightness and stable light output over thousands of hours with excellent mean-time-before-failure (MTBF). With our cutting edge LED technology, our solution also offers dazzling blue and green colors with InGaN (indium gallium nitride) material, and very cost-effective GaP (gallium phosphide) based technology, perfect for low to moderate light output. Avago’s LEDs create brilliant lights with rich life-like colors for our customers’ applications which are longer lasting and at a globally competitive price. They are suitable for almost any applications that customers need today with wide selection of viewing and package options.

Key products include from high brightness and high power LEDs, PLCC surface-mount LEDs, to standard through-hole lamps, surface-mount LEDs, flash LEDs, flexible light strip modules, and various LED displays. These LED Solutions address a wide range of markets, including electronic sign and signal, automotive, solid-state lighting, consumer electronics, home and mobile appliances.

For virtually all established and emerging applications, Avago Technologies has the right LED Solutions to meet your design requirements.





High Brightness Through-hole Lamps

Description

Avago Technologies offers two types of technology based LEDs AllnGaP and InGaN which are suitable for high brightness needs. Through Hole LEDs are offered in 4 mm and 5 mm package.

These devices are casted using advance optical grade epoxy, which provides superior high temperature performance and excellent moisture resistance.

These High Brightness Through Hole LEDs are suitable for application in traffic management, solar powered variable message signs and commercial outdoor advertising video displays.

Features and Benefits

- Excellent product quality and reliability
- Wide range of products
- Competitive pricing
- Wide operating temperature range
- Low power consumption
 - High efficiency, low drive currents and low driving voltages required.
- Colors available for AllnGaP LED lamps
 - Red (626nm), Red Orange (615nm), Orange (605nm) and Amber (590nm)
- Colors available for InGaN LED lamps
 - Blue (470nm), Green (525nm).
- Packaging options
 - Bulk
 - Ammopack

Typical Applications

- Electronic Signs and Signals
 - Traffic Signal
 - Variable Message Sign
 - Pedestrian Signal
 - Work Zone Warning Lights
- Solar Powered Sign
- Commercial Outdoor Advertising
 - Full Color Sign
 - Mono Color Sign

High Brightness 5mm Round LED Lamp

Part Number	Color	Dominant Wavelength (nm)	Viewing Angle (°)	Standoff (Yes/NO)	Luminous Intensity (mcd) @ 20 mA		Package Drawing
					Min.	Max.	
5 mm Round LED Lamps							
8° Viewing Angle							
HLMP-EG08-X1000	Red	626	8	No	7200	21000	A
HLMP-EG10-X1000	Red	626	8	Yes	7200	21000	B
HLMP-EH08-Y2000	Red-Orange	615	8	No	9300	27000	A
HLMP-EH10-Y2000	Red-Orange	615	8	Yes	9300	27000	B
HLMP-EJ08-X1000	Orange	605	8	No	7200	21000	A
HLMP-EJ10-X1000	Orange	605	8	Yes	7200	21000	B
HLMP-EL08-X1000	Amber	590	8	No	7200	21000	A
HLMP-EL10-X1000	Amber	590	8	Yes	7200	21000	B
5 mm Round LED Lamps							
15° Viewing Angle							
HLMP-EG15-UX000	Red	626	15	No	3200	9300	A
HLMP-EG17-UX000	Red	626	15	Yes	3200	9300	B
HLMP-EH15-UX000	Red-Orange	615	15	No	3200	9300	A
HLMP-EH17-UX000	Red-Orange	615	15	Yes	3200	9300	B
HLMP-EJ15-SV000	Orange	605	15	No	1900	5500	A
HLMP-EJ17-SV000	Orange	605	15	Yes	1900	5500	B
HLMP-EL15-VY000	Amber	590	15	No	4200	12000	A
HLMP-EL17-VY000	Amber	590	15	Yes	4200	12000	B
5 mm Round LED Lamps							
23° Viewing Angle							
HLMP-EG24-RU000	Red	626	23	No	1500	4200	A
HLMP-EG26-RU000	Red	626	23	Yes	1500	4200	B
HLMP-EH24-SV000	Red-Orange	615	23	No	1900	5500	A
HLMP-EH26-SV000	Red-Orange	615	23	Yes	1900	5500	B
HLMP-EL24-TW000	Amber	590	23	No	2500	7200	A
HLMP-EL26-TW000	Amber	590	23	Yes	2500	7200	B
5 mm Round LED Lamps							
30° Viewing Angle							
HLMP-EG30-QT000	Red	626	30	No	1150	3200	A
HLMP-EG32-QT000	Red	626	30	Yes	1150	3200	B
HLMP-EH30-RU000	Red-Orange	615	30	No	1500	4200	A
HLMP-EH32-RU000	Red-Orange	615	30	Yes	1500	4200	B
HLMP-EL30-SV000	Amber	590	30	No	1900	5500	A
HLMP-EL32-SV000	Amber	590	30	Yes	1900	5500	B

LED Solutions

High Brightness 5mm Round LED Lamp

Part Number	Color	Dominant Wavelength (nm)	Viewing Angle (°)	Standoff (Yes/NO)	Luminous Intensity (mcd) @ 20 mA		Package Drawing
					Min.	Max.	
5 mm Round LED Lamp							
15° Viewing Angle							
HLMP-EG12-VY0DD	Red	626	15	No	4200	12000	A
HLMP-EG13-VY0DD	Red	626	15	Yes	4200	12000	B
HLMP-EH12-VY0DD	Red-Orange	615	15	No	4200	12000	A
HLMP-EH13-VY0DD	Red-Orange	615	15	Yes	4200	12000	B
HLMP-EL12-X10DD	Amber	590	15	No	7200	21000	A
HLMP-EL13-X10DD	Amber	590	15	Yes	7200	21000	B
HLMP-CM13-Z30DD	Green	525	15	No	12000	35000	A
HLMP-CM14-Z30DD	Green	525	15	Yes	12000	35000	B
HLMP-CB13-VWBDD	Blue	470	15	No	4200	7200	A
HLMP-CB14-VWBDD	Blue	470	15	Yes	4200	7200	B
5 mm Round LED Lamp							
23° Viewing Angle							
HLMP-EG22-WX0DD	Red	626	23	No	5500	9300	A
HLMP-EG23-WX0DD	Red	626	23	Yes	5500	9300	B
HLMP-EH22-TW0DD	Red-Orange	615	23	No	2500	7200	A
HLMP-EH23-TW0DD	Red-Orange	615	23	Yes	2500	7200	B
HLMP-EL22-VXKDD	Amber	590	23	No	4200	9300	A
HLMP-EL23-VXKDD	Amber	590	23	Yes	4200	9300	B
HLMP-CM22-X10DD	Green	525	23	No	7200	21000	A
HLMP-CM25-X10DD	Green	525	23	Yes	7200	21000	B
HLMP-CB22-SV0DD	Blue	470	23	No	1900	5500	A
HLMP-CB25-SV0DD	Blue	470	23	Yes	1900	5500	B
5 mm Round LED Lamp							
30° Viewing Angle							
HLMP-EG35-UV0DD	Red	626	30	No	3200	5500	A
HLMP-EG37-UV0DD	Red	626	30	Yes	3200	5500	B
HLMP-EH35-SV0DD	Red-Orange	615	30	No	1900	5500	A
HLMP-EH37-SV0DD	Red-Orange	615	30	Yes	1900	5500	B
HLMP-EL35-VWKDD	Amber	590	30	No	4200	7200	A
HLMP-EL37-VWKDD	Amber	590	30	Yes	4200	7200	B
HLMP-CM34-X10DD	Green	525	30	No	7200	21000	A
HLMP-CM35-X10DD	Green	525	30	Yes	7200	21000	B
HLMP-CB34-RU0DD	Blue	470	30	No	1500	4200	A
HLMP-CB35-RU0DD	Blue	470	30	Yes	1500	4200	B

LED Solutions

Extra Bright 5mm Round LED Lamp

Part Number	Color	Dominant Wavelength (nm)	Viewing Angle (°)	Standoff (Yes/NO)	Luminous Intensity (mcd) @ 20 mA		Package Drawing
					Min.	Max.	
5 mm Round LED Lamp							
15° Viewing Angle							
HLMP-EG1A-Z10DD	Red	626	15	No	12000	21000	A
HLMP-EG1B-Z10DD	Red	626	15	Yes	12000	21000	B
HLMP-EH1A-Z10DD	Red-Orange	615	15	No	12000	21000	A
HLMP-EH1B-Z10DD	Red-Orange	615	15	Yes	12000	21000	B
HLMP-EL1A-Z1KDD	Amber	590	15	No	12000	21000	A
HLMP-EL1B-Z1KDD	Amber	590	15	Yes	12000	21000	B
5 mm Round LED Lamp							
23° Viewing Angle							
HLMP-EG2A-XY0DD	Red	626	23	No	7200	12000	A
HLMP-EG2B-XY0DD	Red	626	23	Yes	7200	12000	B
HLMP-EH2A-XY0DD	Red-Orange	615	23	No	7200	12000	A
HLMP-EH2B-XY0DD	Red-Orange	615	23	Yes	7200	12000	B
HLMP-EL2A-XYKDD	Amber	590	23	No	7200	12000	A
HLMP-EL2B-XYKDD	Amber	590	23	Yes	7200	12000	B
5 mm Round LED Lamp							
30° Viewing Angle							
HLMP-EG3A-WX0DD	Red	626	30	No	5500	9300	A
HLMP-EG3B-WX0DD	Red	626	30	Yes	5500	9300	B
HLMP-EH3A-WX0DD	Red-Orange	615	30	No	5500	9300	A
HLMP-EH3B-WX0DD	Red-Orange	615	30	Yes	5500	9300	B
HLMP-EL3A-WXKDD	Amber	590	30	No	5500	9300	A
HLMP-EL3B-WXKDD	Amber	590	30	Yes	5500	9300	B

LED Solutions

Extra Bright 5mm Round LED Lamp

Part Number	Color	Dominant Wavelength (nm)	Viewing Angle (°)	Standoff (Yes/NO)	Luminous Intensity (mcd) @ 20 mA		Package Drawing
					Min.	Max.	
5 mm Round LED Lamp							
15° Viewing Angle							
HLMP-CB1A-XY0DD	Blue	470	15	No	7200	12000	C
HLMP-CB1A-XYBDD	Blue	470	15	No	7200	12000	C
HLMP-CB1A-XYCDD	Blue	470	15	No	7200	12000	C
HLMP-CB1B-XY0DD	Blue	470	15	Yes	7200	12000	D
HLMP-CB1B-XYBDD	Blue	470	15	Yes	7200	12000	D
HLMP-CB1B-XYCDD	Blue	470	15	Yes	7200	12000	D
HLMP-CM1A-450DD	Green	525	15	No	35000	59000	C
HLMP-CM1A-45BDD	Green	525	15	No	35000	59000	C
HLMP-CM1A-45CDD	Green	525	15	No	35000	59000	C
HLMP-CM1B-450DD	Green	525	15	Yes	35000	59000	D
HLMP-CM1B-45BDD	Green	525	15	Yes	35000	59000	D
HLMP-CM1B-45CDD	Green	525	15	Yes	35000	59000	D
5 mm Round LED Lamp							
23° Viewing Angle							
HLMP-CB2A-VW0DD	Blue	470	23	No	4200	7200	C
HLMP-CB2A-VWBDD	Blue	470	23	No	4200	7200	C
HLMP-CB2A-VWCDD	Blue	470	23	No	4200	7200	C
HLMP-CB2B-VW0DD	Blue	470	23	Yes	4200	7200	D
HLMP-CB2B-VWBDD	Blue	470	23	Yes	4200	7200	D
HLMP-CB2B-VWCDD	Blue	470	23	Yes	4200	7200	D
HLMP-CM2A-120DD	Green	525	23	No	16000	27000	C
HLMP-CM2A-12BDD	Green	525	23	No	16000	27000	C
HLMP-CM2A-12CDD	Green	525	23	No	16000	27000	C
HLMP-CM2B-120DD	Green	525	23	Yes	16000	27000	D
HLMP-CM2B-12BDD	Green	525	23	Yes	16000	27000	D
HLMP-CM2B-12CDD	Green	525	23	Yes	16000	27000	D
5 mm Round LED Lamp							
30° Viewing Angle							
HLMP-CB3A-UV0DD	Blue	470	30	No	3200	5500	C
HLMP-CB3A-UVBDD	Blue	470	30	No	3200	5500	C
HLMP-CB3A-UVCDD	Blue	470	30	No	3200	5500	C
HLMP-CB3B-UV0DD	Blue	470	30	Yes	3200	5500	D
HLMP-CB3B-UVBDD	Blue	470	30	Yes	3200	5500	D
HLMP-CB3B-UVCDD	Blue	470	30	Yes	3200	5500	D
HLMP-CM3A-Z10DD	Green	525	30	No	12000	21000	C
HLMP-CM3A-Z1BDD	Green	525	30	No	12000	21000	C
HLMP-CM3A-Z1CDD	Green	525	30	No	12000	21000	C
HLMP-CM3B-Z10DD	Green	525	30	Yes	12000	21000	D
HLMP-CM3B-Z1BDD	Green	525	30	Yes	12000	21000	D
HLMP-CM3B-Z1CDD	Green	525	30	Yes	12000	21000	D

LED Solutions

High Brightness Oval LED Lamp

Part Number	Color	Dominant Wavelength (nm)	Viewing Angle (°)	Standoff (Yes/NO)	Luminous Intensity (mcd) @ 20 mA		Lead Frame Orientation	Package Drawing	Remarks
					Min.	Max.			
4 mm Standard Oval LED Lamp									
50° x 100° Viewing Angle									
HLMP-LG65-WX0DD	Red	626	50x100	Yes	1380	1990	Parallel	E	For full color sign application
HLMP-LM65-Z30DD	Green	525	50x100	Yes	2400	5040	Parallel	E	
HLMP-LM65-12BDD	Green	525	50x100	Yes	2900	4200	Parallel	E	
HLMP-LB65-RU0DD	Blue	470	50x100	Yes	550	1150	Parallel	E	
HLMP-LB65-STBDD	Blue	470	50x100	Yes	660	960	Parallel	E	
HLMP-LG63-TX0DD	Red	626	50x100	Yes	800	1990	Parallel	E	For mono color sign application
HLMP-LH65-XY0DD	Red Orange	615	50x100	Yes	1660	2400	Parallel	E	
HLMP-LL65-XYKDD	Amber	590	50x100	Yes	1660	2400	Parallel	E	
4 mm Super Oval LED Lamp									
60° x 120° Viewing Angle									
HLMP-SL20-MP0DD	Amber	590	60x120	Yes	520	1150	Perpendicular	F	For mono color sign application
HLMP-RL20-MP0DD	Amber	590	60x120	Yes	520	1150	Parallel	G	
5 mm Standard Oval LED Lamps									
40° x 100° Viewing Angle									
HLMP-HG64-WX0DD	Red	626	40x100	No	1380	1990	Parallel	H	For full color sign application
HLMP-HG65-WX0DD	Red	626	40x100	Yes	1380	1990	Parallel	I	
HLMP-HM64-12BDD	Green	525	40x100	No	2900	4200	Parallel	H	
HLMP-HM65-12BDD	Green	525	40x100	Yes	2900	4200	Parallel	I	
HLMP-HB64-STBDD	Blue	470	40x100	No	660	960	Parallel	H	
HLMP-HB65-STBDD	Blue	470	40x100	Yes	660	960	Parallel	I	
HLMP-HH64-WX0DD	Red Orange	615	40x100	No	1380	1990	Parallel	H	For mono color sign application
HLMP-HH65-WX0DD	Red Orange	615	40x100	Yes	1380	1990	Parallel	I	
HLMP-HL62-TX0DD	Amber	590	40x100	No	800	1990	Parallel	H	
HLMP-HL63-TX0DD	Amber	590	40x100	Yes	800	1990	Parallel	I	
5 mm Mini Oval LED Lamps									
30° x 70° Viewing Angle									
HLMP-AG64-Z10DD	Red	626	30x70	No	2400	3500	Parallel	J	For full color sign application
HLMP-AG65-Z10DD	Red	626	30x70	Yes	2400	3500	Parallel	K	
HLMP-AM64-34BDD	Green	525	30x70	No	4200	6050	Parallel	J	
HLMP-AM65-34BDD	Green	525	30x70	Yes	4200	6050	Parallel	K	
HLMP-AB64-TUBDD	Blue	470	30x70	No	800	1150	Parallel	J	
HLMP-AB65-TUBDD	Blue	470	30x70	Yes	800	1150	Parallel	K	
HLMP-AH64-Z10DD	Red Orange	615	30x70	No	2400	3500	Parallel	J	For mono color sign application
HLMP-AH65-Z10DD	Red Orange	615	30x70	Yes	2400	3500	Parallel	K	
HLMP-AJ64-YZ0DD	Orange	605	30x70	No	1990	2400	Parallel	J	
HLMP-AJ65-YZ0DD	Orange	605	30x70	Yes	1990	2400	Parallel	K	
HLMP-AL64-23KDD	Amber	590	30x70	No	3500	5040	Parallel	J	
HLMP-AL65-23KDD	Amber	590	30x70	Yes	3500	5040	Parallel	K	

LED Solutions

High Brightness Lamps

High Brightness LED Lamps 1.3:1 Intensity Bin Limits (mcd at 20mA)

Bin ID	Min.	Max.
D	65	85
E	85	110
F	110	140
G	140	180
H	180	240
J	240	310
K	310	400
L	400	520
M	520	680
N	680	880
P	880	1150
Q	1150	1500
R	1500	1900
S	1900	2500
T	2500	3200
U	3200	4200
V	4200	5500
W	5500	7200
X	7200	9300
Y	9300	12000
Z	12000	16000
1	16000	21000
2	21000	27000
3	27000	35000
4	35000	45000
5	45000	59000
6	59000	76000

Tolerance for each bin limit is $\pm 15\%$

High Brightness LED Lamps 1.2:1 Intensity Bin Limits (mcd at 20mA)

Bin ID	Min.	Max.
P	380	460
Q	460	550
R	550	660
S	660	800
T	800	960
U	960	1150
V	1150	1380
W	1380	1660
X	1660	1990
Y	1990	2400
Z	2400	2900
1	2900	3500
2	3500	4200
3	4200	5040
4	5040	6050
5	6050	7260
6	7260	8710
7	8710	10460
8	10460	12560
9	12560	15100

Tolerance for each bin limit is $\pm 15\%$

Color Bin Structure

Bin ID	Wavelength (nm)		Remark
	Min.	Max.	
Red			
--	618.0	630.0	Type 1
--	620.0	630.0	Type 2
Red Orange *1			
--	612.0	619.0	Type 1
--	612.0	621.7	Type 2
Orange *1			
1	600.0	604.0	Type 1
2	604.0	608.0	
3	608.0	612.0	
2	599.5	604.5	Type 2
4	604.5	610.5	
Amber			
1	584.5	587.0	
2	587.0	589.5	
4	589.5	592.0	
6	592.0	594.5	
Green *1			
1	520.0	524.0	Type 1
2	524.0	528.0	Type 1
3	528.0	532.0	Type 1
4	532.0	536.0	Type 1
5	536.0	540.0	Type 1
1	519.0	523.0	Type 2
2	523.0	527.0	Type 2
3	527.0	531.0	Type 2
4	531.0	535.0	Type 2
5	535.0	539.0	Type 2
Blue			
1	460.0	464.0	
2	464.0	468.0	
3	468.0	472.0	
4	472.0	476.0	
5	476.0	480.0	

Note 1: There are 2 types of color bin limits. Please refer to individual datasheet for details.

Tolerance for each bin limit is $\pm 0.5\text{nm}$

High Brightness Lamps Package Drawing

5 mm Round LED Lamp

A: Non-standoff

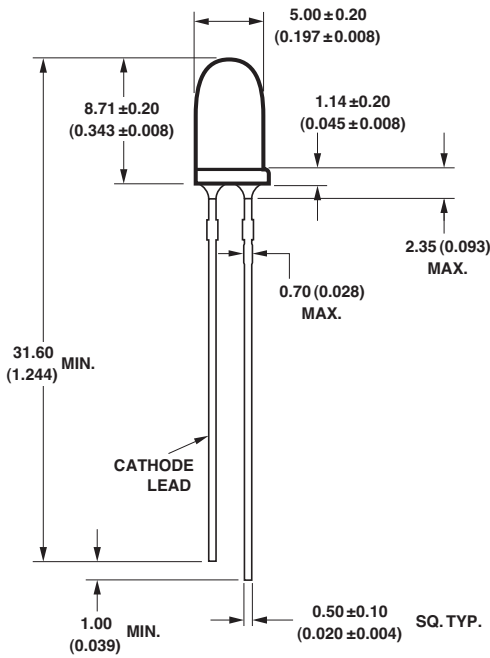

B: Standoff

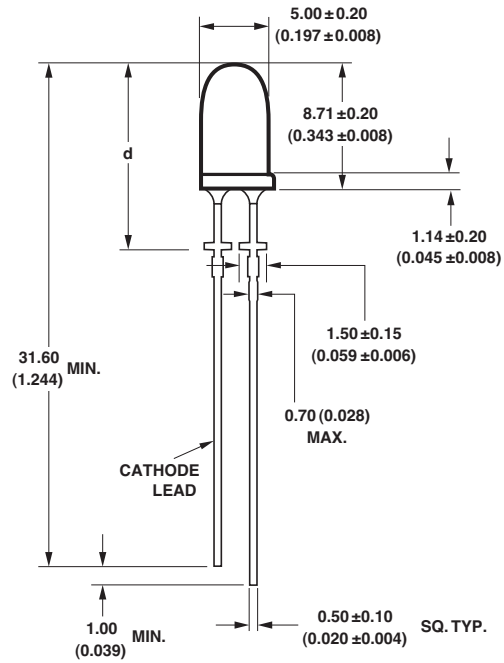

NOTE:
Please refer to individual datasheet for dimension D.

5 mm Round LED Lamp

C: Non-standoff

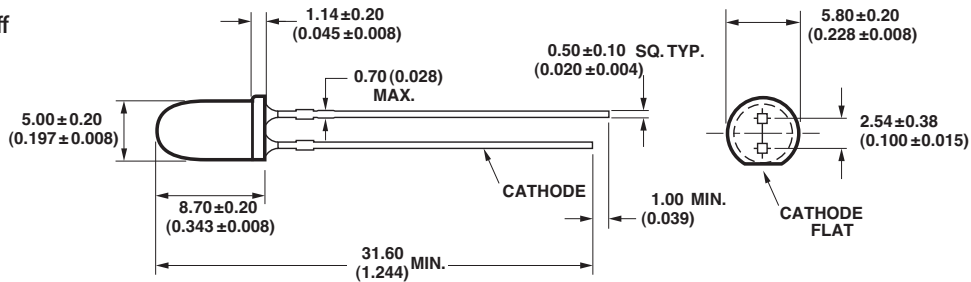

D: Standoff

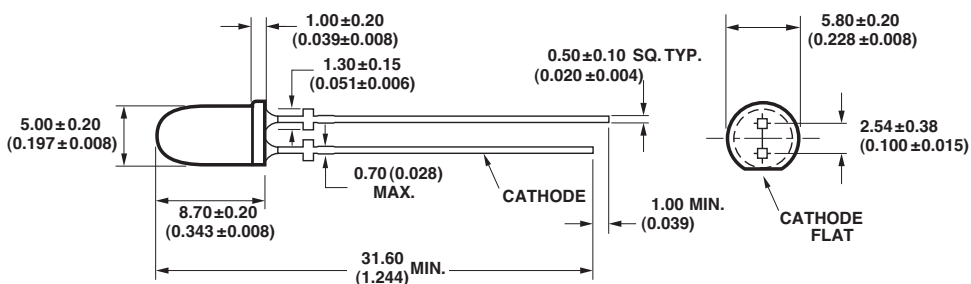

LED Solutions

4 mm Standard Oval LED Lamp 50° x 100° Viewing Angle

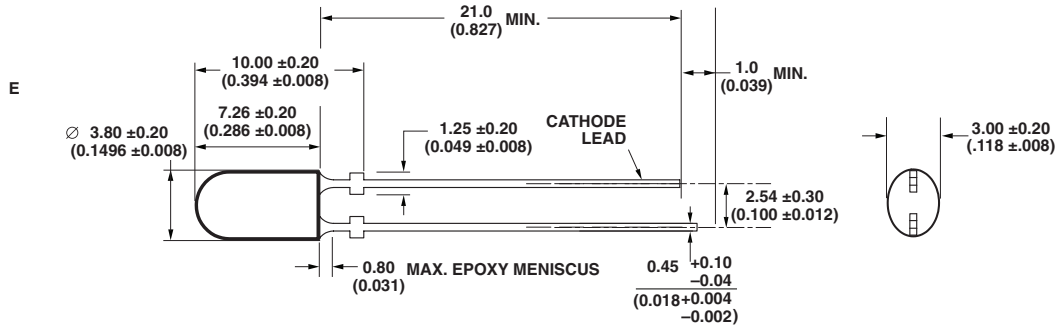

4 mm Super Oval LED Lamp 60° x 120° Viewing Angle

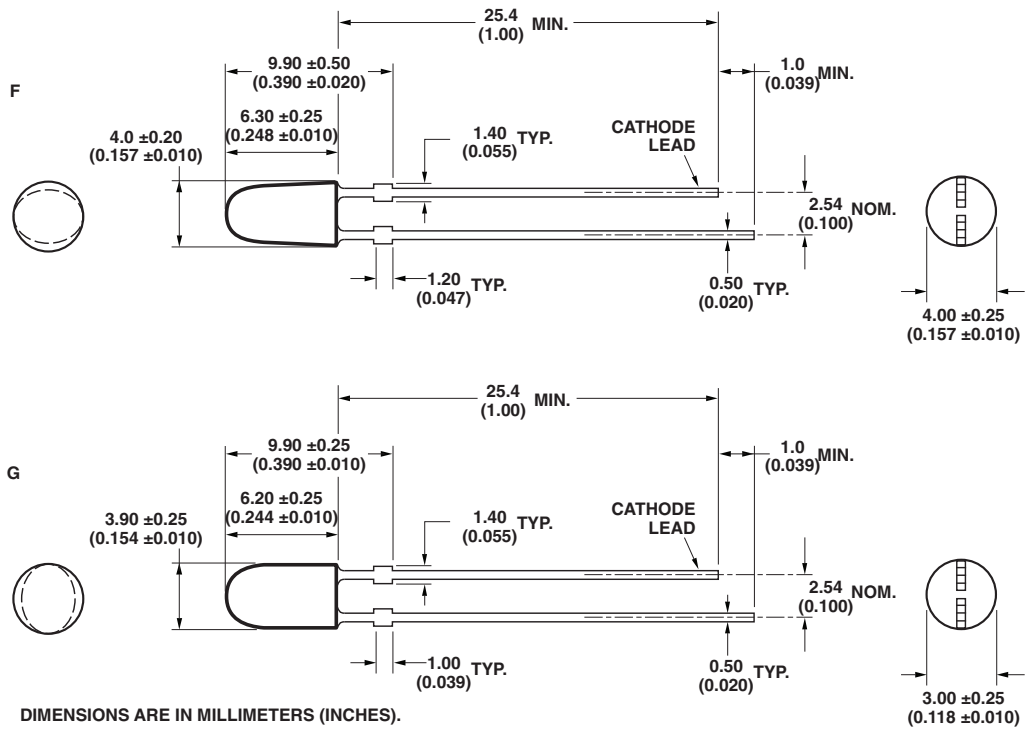

5 mm Standard Oval LED Lamp 40° x 100° Viewing Angle

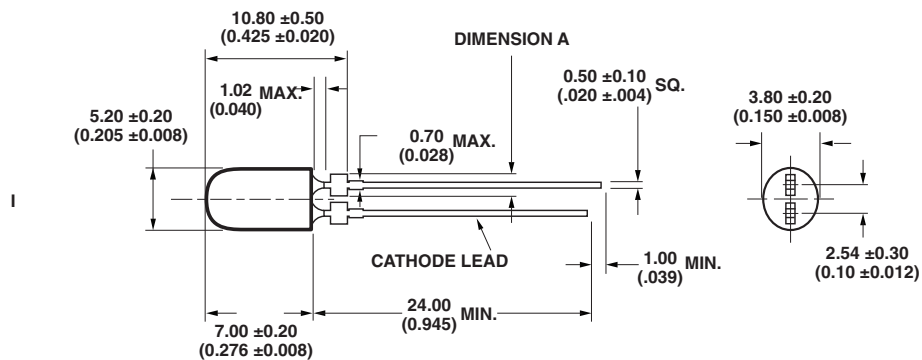
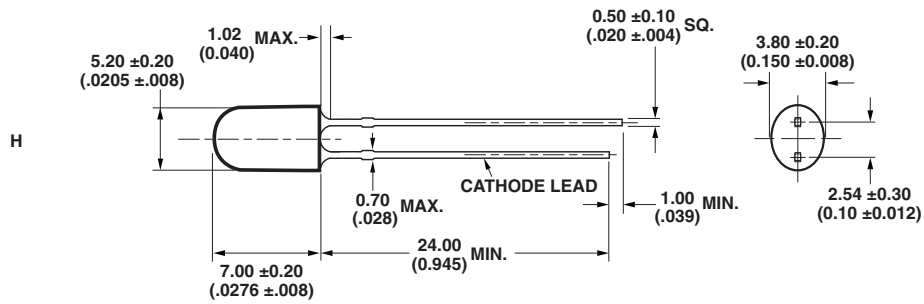

NOTE:
Please refer to individual datasheet for dimension A.

5mm Mini Oval LED Lamp 30° x 70° Viewing Angle

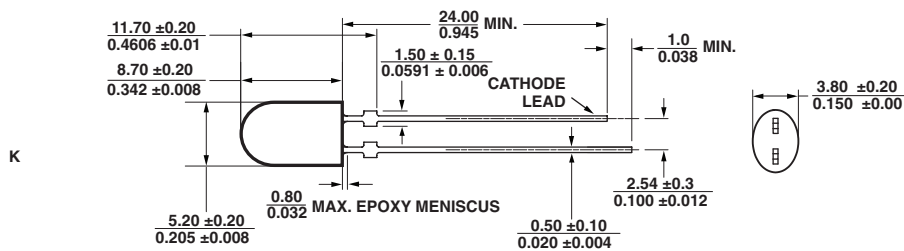
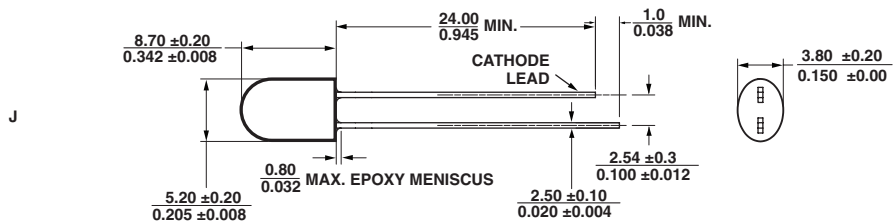

NOTE:
For all package drawings above, the dimension are in millimeters (inches).



Surface Mount PLCC LEDs

Description

This surface-mount LED comes in PLCC standard package dimension. It has a substrate made up of a molded plastic reflector sitting on top of a bent lead frame. The die is attached within the reflector cavity and the cavity is encapsulated by an Avago Technologies proprietary epoxy or silicone material.

The PLCC SMT LED products with a viewing angle of 120° is ideal for instruments/switch/icon backlighting. With additional lens in 30° and 50° variants, these products are especially fitting to applications for traffic lights, CHMSL and displays. Its external reflector makes easy coupling with light pipe/light guide for an even-larger area backlighting. The package design coupled with careful selection of component materials allow these products to perform with high reliability in a larger temperature range -40°C to 100°C. The high reliability feature is crucial to Automotive Interior and Indoor ESS.

The surface-mount LED is designed to be compatible with industrial reflow soldering process.

Features and Benefits

- Industry Standard PLCC SMT package
 - No change in existing board layout, drop-in replacement for the existing PLCC SMT LEDs
- High brightness using AlInGaP and InGaN dice technologies
- Available in various colors
 - Red, Red Orange, Orange, Amber, Yellow Green, Emerald Green, Green, Blue and White
 - Bi-colors in various combinations
 - Tri-colors in Red, Green and Blue
- Available in viewing angle of 30°, 50° and 120°
 - Well-suited for backlighting applications
- High volume, high reliability
 - Cost-effective solution
- Black surface and black body options to enhance contrast for display application

Target Markets and Applications

- Interior automotive
 - Instrument panel backlighting
 - Central console backlighting
 - Cabin backlighting
- Exterior automotive
 - Turn signals
 - Side repeater lamps
 - CHMSLs (center high-mounted stop light)
 - Rear combination lamps
 - Puddle lights
- Electronic Signs and Signals
 - Interior full color sign
 - Variable message sign
- Office Automation, Electrical Appliances, Industrial Equipment
 - Front panel backlighting
 - Push button backlighting
 - Display backlighting

LED Solutions

PLCC Surface Mount LEDs

PLCC-2

Part Number	Color	Dominant Wavelength λ_p (nm)	Viewing Angle $2\theta_{1/2}$ (°)	I_v @ 20 mA		V_f @ 20 mA Typ. (V)
				Min. (mcd)	Typ. (mcd)	
HSMS-A100-L00J1	GaP Red	626	120	10	15	2.2
HSMH-A100-N00J1	AlGaAs Red	637	120	25	50	1.9
HSMC-A100-Q00J1	AllnGaP Red	626	120	63	100	1.9
HSMC-A100-R00J1	AllnGaP Red	626	120	100	140	1.9
HSMC-A101-S00J1	AllnGaP Red	626	120	160	220	1.9
HSMZ-A100-T00J1	AllnGaP Red	630	120	250	350	2.2
HSMJ-A100-Q00J1	AllnGaP Red Orange	615	120	63	100	1.9
HSMJ-A101-S00J1	AllnGaP Red Orange	615	120	160	200	1.9
HSMV-A100-T00J1	AllnGaP Red Orange	617	120	250	350	2.2
HSMD-A100-L00J1	GaP Orange	602	120	10	15	2.2
HSML-A100-Q00J1	AllnGaP Orange	605	120	63	100	1.9
HSML-A101-S00J1	AllnGaP Orange	605	120	160	220	1.9
HSMY-A100-L00J1	GaP Amber	585	120	10	12	2.2
HSMA-A100-Q00J1	AllnGaP Amber	590	120	63	100	1.9
HSMA-A101-S00J1	AllnGaP Amber	590	120	160	220	1.9
HSMU-A100-S00J1	AllnGaP Amber	592	120	160	320	2.2
HSMG-A100-J02J1	GaP Yellow Green	569	120	4	18	2.2
HSME-A100-M02J1	AllnGaP Yellow Green	570	120	16	70	1.9
HSMG-A100-H01J1	GaP Emerald Green	560	120	2.5	8	2.2
HSME-A100-L01J1	AllnGaP Emerald Green	560	120	10	40	1.9
HSMH-A101-R00J1	InGaN Green	525	120	100	200	3.4
HSMH-A100-S00J1	InGaN Green	525	120	160	350	3.4
HSMN-A101-N00J1	InGaN Blue	470	120	25	50	3.4
HSMN-A100-P00J1	InGaN Blue	470	120	40	70	3.4

Notes:

1. The luminous intensity I_v is measured at the mechanical axis of the lamp package. The actual peak of the spatial radiation pattern may not be aligned with this axis.
2. The dominant wavelength, λ_p , is derived from the CIE Chromaticity Diagram and represents the color of the device.
3. $\theta_{1/2}$ is the off-axis angle where the luminous intensity is 1/2 the peak intensity.

PLCC-2 White

Part Number	Color	Chromaticity Coordinates		Viewing Angle $2\theta_{1/2}$ (°)	I_v @ 20 mA		V_f @ 20 mA Typ. (V)
		x	y		Min. (mcd)	Typ. (mcd)	
HSMW-A101-R50J1	InGaN White	0.31	0.31	120	100	—	3.4
HSMW-A100-T50J1	InGaN White	0.31	0.31	120	250	—	3.4

Notes:

1. The luminous intensity I_v is measured at the mechanical axis of the lamp package. The actual peak of the spatial radiation pattern may not be aligned with this axis.
2. The chromaticity coordinates are derived from the CIE 1931 Chromaticity Diagram and represents the perceived color of the device.
3. $\theta_{1/2}$ is the off-axis angle where the luminous intensity is 1/2 the peak intensity.

PLCC Surface Mount LEDs

Power PLCC-4

Part Number	Color	Dominant Wavelength $\lambda_b^{[1]}$ (nm)	Viewing Angle $2\theta_{1/2}^{[2]}$ (Degrees)	Min. I_v (mcd)	Max. I_v (mcd)	Typ. V_F (V)	Test Current (mA)
HSMC-A400-S30M1	AllInGaP Red	626	120	160	395	2.2	50
HSMC-A401-T40M1	AllInGaP Red	626	120	250	800	2.2	50
HSMC-A401-T80M1	AllInGaP Red	626	120	310	1000	2.2	50
HSMZ-A400-U80M1	AllInGaP Red	630	120	500	1600	2.8	50
HSMJ-A401-T40M1	AllInGaP Red Orange	615	120	250	800	2.2	50
HSMJ-A401-U40M1	AllInGaP Red Orange	615	120	400	1260	2.2	50
HSMV-A400-U80M1	AllInGaP Red Orange	617	120	500	1600	2.8	50
HSMJ-A401-U40M1	AllInGaP Orange	605	120	400	1260	2.2	50
HSMV-A400-T35M1	AllInGaP Amber	590	120	250	620	2.2	50
HSMV-A401-U45M1	AllInGaP Amber	590	120	400	1260	2.2	50
HSMU-A400-U85M1	AllInGaP Amber	592	120	500	1600	2.8	50
HSME-A401-P4PM1	AllInGaP Emerald Green	567	120	40	130	2.2	50
HSMV-A400-T8YM2	InGaN Green	525	120	310	1000	3.8	30
HSMN-A400-S4QM2	InGaN Blue	470	120	180	450	3.8	30

Notes:

1. The dominant wavelength, λ_b , is derived from the CIE Chromaticity Diagram and represents the color of the device.
2. $\theta_{1/2}$ is the off-axis angle where the luminous intensity is 1/2 the peak intensity.
3. The luminous intensity, I_v , is measured at the mechanical axis of the lamp package. The actual peak of the spatial radiation pattern may not be aligned with this axis.

Power PLCC-4 White

Part Number	Color	Chromaticity Coordinates		Viewing Angle $2\theta_{1/2}$ (°)	I_v @ 30 mA			VF @ 30 mA Typ. (V)
		x	y		Min. (mcd)	Typ. (mcd)	Max. (mcd)	
HSMW-A400-U00M2	InGaN White	0.31	0.31	120	450.00	700.00	-	3.8
ASMT-SWBM-NU803 ^[5]	InGaN White	0.318	0.318	120	560.00	1100.00	1400.00	3.5

Notes:

1. The luminous intensity I_v is measured at the mechanical axis of the lamp package. The actual peak of the spatial radiation pattern may not be aligned with this axis.
2. I_v Tolerance = $\pm 12\%$
3. The chromaticity coordinates are derived from the CIE 1931 Chromaticity Diagram and represent the perceived color of the device.
4. $\theta_{1/2}$ is the off-axis angle where the luminous intensity is 1/2 the peak intensity.
5. Long Life White Device

Power PLCC-4 with Lens

Part Number	Color	Dominant Wavelength $\lambda_b^{[1]}$ (nm)	Viewing Angle $2\theta_{1/2}$ (°)	Min. I_v (mcd)	Max. I_v (mcd)	Typ. V_F (V)	Test Current (mA)
HSMC-A431-Y80M1	AllInGaP Red	626	30	3550	9000	2.2	50
HSMC-A431-X90M1	AllInGaP Red	626	30	2240	7150	2.2	50
HSMC-A461-V00M1	AllInGaP Red	626	50	715	—	2.2	50
HSMJ-A430-W50M1	AllInGaP Red Orange	615	30	1125	3550	2.2	50
HSMJ-A431-X90M1	AllInGaP Red Orange	615	30	2240	7150	2.2	50
HSMV-A430-Y90M1	AllInGaP Red Orange	617	30	3500	11250	2.8	50
HSMJ-A461-W40M1	AllInGaP Red Orange	615	50	1125	2850	2.2	50
HSMJ-A431-X90M1	AllInGaP Orange	605	30	2240	7150	2.2	50
HSMJ-A461-W40M1	AllInGaP Orange	605	50	1125	2850	2.2	50
HSMV-A431-Y00M1	AllInGaP Amber	590	30	2850	—	2.2	50
HSMA-A431-Z50M1	AllInGaP Amber	590	30	4500	14000	2.2	50
HSMA-A461-X83M1	AllInGaP Amber	590	50	2240	5600	2.2	50
HSMV-A430-W90M2	InGaN Green	525	30	1400	4500	3.9	30
HSMN-A430-U50M2	InGaN Blue	470	30	450	1400	3.9	30
HSMN-A431-T50M2	InGaN Blue	470	30	285	900	3.9	30

Notes:

1. The luminous intensity, I_v , is measured at the mechanical axis of the lamp package. The actual peak of the spatial radiation pattern may not be aligned with this axis.
2. I_v tolerance $\pm 12\%$
3. The dominant wavelength, λ_b , is derived from the CIE Chromaticity Diagram and represents the color of the device.
4. $\theta_{1/2}$ is the off-axis angle where the luminous intensity is 1/2 the peak intensity.

LED Solutions

PLCC Surface Mount LEDs

Bicolor PLCC-4

Part Number	Color	Min. I_v @ 20mA		Typ. I_v (mcd) @ 20mA
		Bin ID	mcd	
HSMF-A201-A00J1	GaP Red	K2	8	16
	GaP Yellow Green	L1	10	20
HSMF-A202-A00J1	GaP Red	K2	8	16
	GaP Yellow	K1	6.3	12
HSMF-A203-A00J1	GaP Red	K2	8	16
	GaP Emerald Green	J1	4	8
HSMF-A204-A00J1	GaP Orange	K2	8	16
	GaP Yellow Green	L1	10	20
HSMF-A205-A00J1	GaP Orange	K2	8	16
	GaP Emerald Green	J1	4	8
HSMF-A206-A00J1	GaP Yellow	K2	8	16
	GaP Yellow Green	L1	10	20
HSMF-A211-A00J1	AlGaAs Red	L2	12.5	25
	GaP Yellow Green	L1	10	20
HSMF-A212-A00J1	AlGaAs Red	L2	12.5	25
	GaP Yellow	K1	6.3	12
	AllnGaP Red	P1	40	80
HSMF-A222-A00J1	AllnGaP Red	P1	40	80
	AllnGaP Amber	P1	40	80
HSMF-A226-A00J1	AllnGaP Amber	P2	50	100
	AllnGaP Yellow Green	M2	20	60

Tricolor PLCC-4

Part Number	Color	Min. I_v @ 20mA		Typ. I_v (mcd) @ 20mA
		Bin ID	mcd	
HSMF-A301-A00J1	GaP Red	K2	8	13
	GaP Yellow Green	L2	12.5	20
	GaN Blue	K2	8	10
HSMF-A341-A00J1	AllnGaP Red	P1	40	80
	InGaN Green	R1	100	160
	InGaN Blue	N1	25	40

Super 0.5W Power PLCC-4

Part Number	Color	Dominant Wavelength λ_b [1] (nm)	Viewing Angle $2\theta_{1/2}$ [2] (°)	Flux Bin	Min. Flux (lm)	Max. Flux (lm)	Typ. V_f (V)	Test Current (mA)
ASMT-QAB2-FDE0E	AllnGaP Amber	594.5	120	D	9.00	11.50	2.70	150
				E	11.50	15.00		
ASMT-QHB2-FEFOE	AllnGaP Red Orange	617.0	120	E	11.50	15.00	2.70	150
				F	15.00	19.50		
ASMT-QRB2-FCDOE	AllnGaP Red	624.0	120	C	7.00	9.00	3.10	150
				D	9.00	11.50		
ASMT-QBBE-NOBOE**	InGaN Blue	464.5	120	O	3.40	4.30	3.6	150
				A	4.30	5.50		
				B	5.50	7.00		
ASMT-QGBE-NFHOE**	InGaN Green	522.0	120	F	15.00	19.50	3.6	150
				G	19.50	25.50		
				H	25.50	33.00		

Notes:

1. The dominant wavelength, λ_b , is derived from the CIE Chromaticity diagram and represents the color of the device.
2. $\theta_{1/2}$ is the off-axis angle where the luminous intensity is 1/2 the peak intensity.
3. Φ_v is the total luminous flux output as measured with an integrating sphere at mono pulse conditions.
4. Tolerance = $\pm 12\%$.

**Not for Japan

LED Solutions

PLCC Surface Mount LEDs

Super 0.5W White Power PLCC-4

Part Number	Color	Chromaticity Coordinates		Viewing Angle $2\theta_{1/2}$ (°)	Flux Bin	Min. Flux (lm)	Max. Flux (lm)	Typ. V_F (V)	Test Current (mA)
		x	y						
ASMT-QWBE-NFH0E**	InGaN Cool White	0.33	0.33	120	F	15.00	19.50	3.6	150
					G	19.50	25.50		
					H	25.50	33.00		
ASMT-QYBE-NEG0E**	InGaN Warm White	0.44	0.41	120	E	11.50	15.00	3.6	150
					F	15.00	19.50		
					G	19.50	25.50		
ASMT-QWBC-NHJ0E**	InGaN Cool White	0.31	0.31	120	H	25.50	33.00	3.4	150
					J	33.00	43.00		
ASMT-QYBC-NGJ0E**	InGaN Warm White	0.40	0.39	120	G	19.50	25.50	3.4	150
					H	25.50	33.00		
					J	33.00	43.00		

Notes:

- $\theta_{1/2}$ is the off-axis angle where the luminous intensity is 1/2 the peak intensity.
- Φ_V is the total luminous flux output as measured with an integrating sphere at mono pulse conditions.
- Tolerance = $\pm 12\%$.

**Not for Japan

High Brightness Tricolor PLCC4 & PLCC6

Part Number	Color	Package	Viewing Angle (°)	Dominant Wavelength (nm)	Min Intensity (mcd) @ 20mA		Typ IV @ 20mA (mcd)	Features
					Bin	mcd		
ASMT-QTBO-0AA02	Red	PLCC-4	120	626	U1	450	620	Black Surface
	Green			525	V2	900	1200	
	Blue			470	S2	224	280	
ASMT-QTCO-0AA02	Red	PLCC-4	115	626	S1	180	315	Black Body
	Green			525	T1	285	470	
	Blue			470	R1	112.5	140	
ASMT-YTBO-0AA02	Red	PLCC-6	115	626	U1	450	620	Black Surface
	Green			525	V2	900	1200	
	Blue			470	S2	224	280	

LED Solutions

PLCC2, Power PLCC-4, Bicolor PLCC-4 and Tricolor PLCC-4

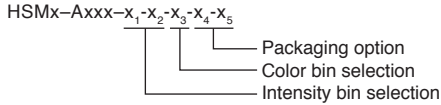

Intensity Bin Select (X₁, X₂)

Individual reel will contain parts from 1 half bin only. Single color (see data sheet for bicolor and tricolor).

X ₁	Minimum Iv Bin
X ₂	Number of half bins
0	Full Distribution
2	2 half bins starting from X ₁
3	3 half bins starting from X ₁
4	4 half bins starting from X ₁
5	5 half bins starting from X ₁
6	2 half bins starting from X ₂
7	3 half bins starting from X ₂
8	4 half bins starting from X ₂
9	5 half bins starting from X ₂

Color Bin Selection (X₃)

Individual reel will contain parts from 1 full bin only. Single color (see data sheet for bicolor and tricolor).

X ₃	
0	Full Distribution
Z	A and B only
Y	B and C only
W	C and D only
V	D and E only
U	E and F only
T	F and G only
S	G and H only
Q	A, B and C only
P	B, C and D only
N	C, D and E only
M	D, E and F only
L	E, F and G only
K	F, G and H only
1	A, B, C and D only
2	E, F, G and H only
3	B, C, D and E only
4	C, D, E and F only
5	A, B, C, D and E only
6	B, C, D, E and F only

Color Bin Limits for HSMW-Axxx

Bin ID	Limits (Chromaticity Coordinates)
A	X 0.352 0.365 0.365 0.352
	Y 0.377 0.395 0.360 0.341
B	X 0.340 0.352 0.352 0.340
	Y 0.360 0.377 0.341 0.325
C	X 0.327 0.340 0.340 0.327
	Y 0.342 0.360 0.325 0.306
D	X 0.315 0.327 0.327 0.315
	Y 0.325 0.342 0.306 0.290
E	X 0.302 0.315 0.315 0.302
	Y 0.307 0.325 0.290 0.271
F	X 0.290 0.302 0.302 0.290
	Y 0.290 0.307 0.271 0.255

Tolerance of each bin limit = ± 0.02.

Intensity Bin Limits

Bin ID	Intensity (mcd)	
	Min.	Max.
J1	4.50	5.60
J2	5.60	7.20
K1	7.20	9.00
K2	9.00	11.20
L1	11.20	14.00
L2	14.00	18.00
M1	18.00	22.40
M2	22.40	28.50
N1	28.50	35.50
N2	35.50	45.00
P1	45.00	56.00
P2	56.00	71.50
Q1	71.50	90.00
Q2	90.00	112.50
R1	112.50	140.00
R2	140.00	180.00
S1	180.00	224.00
S2	224.00	285.00
T1	285.00	355.00
T2	355.00	450.00
U1	450.00	560.00
U2	560.00	715.00
V1	715.00	900.00
V2	900.00	1125.00
W1	1125.00	1400.00
W2	1400.00	1800.00
X1	1800.00	2240.00
X2	2240.00	2850.00
Y1	2850.00	3550.00
Y2	3550.00	4500.00
Z1	4500.00	5600.00
Z2	5600.00	7150.00
11	7150.00	9000.00
12	9000.00	11250.00
21	11250.00	14000.00
22	14000.00	18000.00

Tolerance of each bin limit = ± 12%

Color Coordinates Chart for HSMW-Axxx

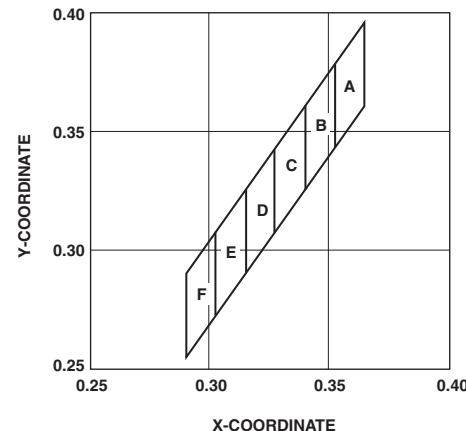

Color Bin Limits

Color/Bin	Wavelength (nm)	
	Min.	Max.
Blue		
A	460.0	465.0
B	465.0	470.0
C	470.0	475.0
D	475.0	480.0
Cyan		
A	490.0	495.0
B	495.0	500.0
C	500.0	505.0
D	505.0	510.0
Green		
A	515.0	520.0
B	520.0	525.0
C	525.0	530.0
D	530.0	535.0
Yellow Green/Emerald Green		
A	552.5	555.5
B	555.5	558.5
C	558.5	561.5
D	561.5	564.5
E	564.5	567.5
F	567.5	570.5
G	570.5	573.5
H	573.5	576.5
Amber		
A	582.0	584.5
B	584.5	587.0
C	587.0	589.5
D	589.5	592.0
E	592.0	594.5
F	594.5	597.0
Orange		
A	597.0	600.0
B	600.0	603.0
C	603.0	606.0
D	606.0	609.0
E	609.0	612.0
Red Orange		
A	611.0	616.0
B	616.0	620.0
Red		
Full Distribution	620	635

Tolerance of each bin limit = ± 1nm

Tricolor/Power PLCC-4

1	Cathode (Color 1)
2	Common Anode
3	Cathode (Color 3)
4	Cathode (Color 2)

Bicolor PLCC-4

1	Cathode (Color 1)
2	Anode (Color 1)
3	Cathode (Color 2)
4	Anode (Color 2)

LED Solutions

PLCC Surface Mount LEDs

Packaging Option (X_4, X_5)

X_4, X_5	Test Current	Package Type	Reel Size
M1	50 mA	Top Mount	7/13 Inch
M2	30 mA	Top Mount	7/13 Inch
J1	20 mA	Top Mount	7 Inch
J4	20 mA	Top Mount	13 Inch
H1	20 mA	Reverse Mount	7 Inch
H4	20 mA	Reverse Mount	13 Inch

Long Life PLCC-4 ASMT-SWBM

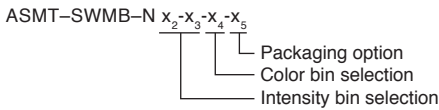

Intensity Bin Selection (X_2, X_3)

Individual reel will contain parts from one half bin only.

X_2	Minimum I_v Bin
0	Full Distribution
2	2 half bins starting from $X_2, 1$
3	3 half bins starting from $X_2, 1$
4	4 half bins starting from $X_2, 1$
5	5 half bins starting from $X_2, 1$
6	2 half bins starting from $X_2, 2$
7	3 half bins starting from $X_2, 2$
8	4 half bins starting from $X_2, 2$
9	5 half bins starting from $X_2, 2$

Intensity Bin Limits

Bin ID	Min. (mcd)	Max. (mcd)
N1	28.50	35.50
N2	35.50	45.00
P1	45.00	56.00
P2	56.00	71.50
Q1	71.50	90.00
Q2	90.00	112.50
R1	112.50	140.00
R2	140.00	180.00
S1	180.00	224.00
S2	224.00	285.00
T1	285.00	355.00
T2	355.00	450.00
U1	450.00	560.00
U2	560.00	715.00
V1	715.00	900.00
V2	900.00	1125.00
W1	1125.00	1400.00
W2	1400.00	1800.00

Tolerance of each bin limit = $\pm 12\%$

Color Bin Selection (X_4)

Individual reel will contain parts from one full bin only.

X_4	Color Bin Selection
0	Full Distribution
A	1 and 2 only
B	2 and 3 only
C	3 and 4 only
D	4 and 5 only
E	5 and 6 only
F	6 and 7 only
G	1, 2 and 3 only
H	2, 3 and 4 only
J	3, 4 and 5 only
K	4, 5 and 6 only
L	5, 6 and 7 only
M	1, 2, 3 and 4 only
N	2, 3, 4 and 5 only
P	3, 4, 5 and 6 only
Q	4, 5, 6 and 7 only
R	1, 2, 3, 4 and 5 only
S	2, 3, 4, 5 and 6 only
T	3, 4, 5, 6, and 7 only
U	1, 2, 3, 4, 5 and 6 only
V	2, 3, 4, 5, 6 and 7 only
Z	Special Color Bin

Packaging Option (X_5)

X_5	Test Current	Package Type	Reel Size
3	30 mA	Top Mount	7 inch

V_F Bin Limits

Bin ID	Min.	Max.
S3	3.20	3.80
S4	3.80	4.35

Tolerance of each bin limit = $\pm 0.1V$

Color Bin Limits

Bin ID	Limits (Chromaticity Coordinates)				
1	x	0.296	0.291	0.310	0.313
	y	0.259	0.268	0.297	0.284
2	x	0.291	0.285	0.307	0.310
	y	0.268	0.279	0.312	0.297
3	x	0.313	0.310	0.330	0.330
	y	0.284	0.297	0.330	0.310
4	x	0.310	0.307	0.330	0.330
	y	0.297	0.312	0.347	0.330
5	x	0.330	0.330	0.338	0.352
	y	0.310	0.330	0.342	0.344
6	x	0.330	0.330	0.347	0.345
	y	0.330	0.347	0.371	0.352
7	x	0.352	0.338	0.364	0.360
	y	0.344	0.342	0.380	0.357
8	x	0.345	0.347	0.367	0.364
	y	0.352	0.371	0.401	0.380

Tolerance of each bin limit = ± 0.02

Color Coordinates Chart for ASMT-SWBM

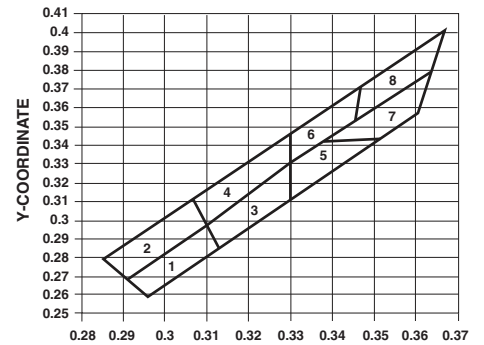

LED Solutions

High Brightness Tricolor PLCC-4 and PLCC-6

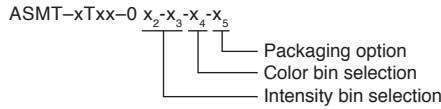

Intensity Bin Selection (X₂X₃) For ASMT-QTBO/YTBO

Individual reel will contain parts from one half bin only.

X ₂	Min Iv Bin (Minimum Intensity Bin)		
	Red	Green	Blue
0	0	0	0
A	U1	V2	S2

X ₃	Number of Half Bin from X ₂		
	Red	Green	Blue
0	0	0	0
A	4	4	4

Note: 0 represents no maximum bin limit

For ASMT-QTCO

X ₂	Min Iv Bin (Minimum Intensity Bin)		
	Red	Green	Blue
0	0	0	0
A	S1	T1	R1

X ₃	Number of Half Bin from X ₂		
	Red	Green	Blue
0	0	0	0
A	4	4	4

Color Bin Selection (X₄)

Individual reel will contain parts from one full bin only.

X ₄	Color Bin Combinations		
	Red	Green	Blue
0	Full Distribution	C & D	B & C

Intensity Bin Limits

Bin ID	Min (mcd)	Max (mcd)
R1	112.5	140
R2	140	180
S1	180	224
S2	224	285
T1	285	355
T2	355	450
U1	450	560
U2	560	715
V1	715	900
V2	900	1125
W1	1125	1400
W2	1400	1800
X1	1800	2240

Tolerance of each bin limit = ± 12%

Color Bin Limits

Red	Min (nm)	Max (nm)
Full Distribution	618	628

Green	Min (nm)	Max (nm)
C	525	530
D	530	535

Blue	Min (nm)	Max (nm)
B	465	470
C	470	475

Tolerance of each bin limit = ± 1 nm

Packaging Option (X₅)

Please refer to respective datasheet for related information.

LED Solutions

Super 0.5W Power PLCC-4

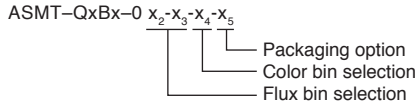

Flux Bin Selection (X₂, X₃)

Individual reel will contain parts from one bin only

X ₂	Min Flux Bin
X ₃	Max Flux Bin

Flux Bin Limits

Bin ID	Min. (lm)	Max. (lm)
0	3.40	4.30
A	4.30	5.50
B	5.50	7.00
C	7.00	9.00
D	9.00	11.50
E	11.50	15.00
F	15.00	19.50
G	19.50	25.50
H	25.50	33.00
J	33.00	43.00
K	43.00	56.00
L	56.00	73.00

Tolerance of each bin limit = ± 12%

Color Bin Selection (X₄)

Individual reel will contain parts from one full bin only.

X ₄	
0	Full Distribution
A	1 and 2 only
B	2 and 3 only
C	3 and 4 only
D	4 and 5 only
E	5 and 6 only
G	1, 2 and 3 only
H	2, 3 and 4 only
J	3, 4 and 5 only
K	4, 5 and 6 only
M	1, 2, 3 and 4 only
N	2, 3, 4 and 5 only
P	3, 4, 5 and 6 only
R	1, 2, 3, 4 and 5 only
S	2, 3, 4, 5 and 6 only
Z	Special Color Bin

Color Bin Limits

Color/Bin	Wavelength (nm)	
	Min.	Max.
Blue		
1	460.0	465.0
2	465.0	470.0
3	470.0	475.0
4	475.0	480.0
Green		
1	515.0	520.0
2	520.0	525.0
3	525.0	530.0
4	530.0	535.0
Amber		
2	583.0	586.0
3	586.0	589.0
4	589.0	592.0
5	592.0	595.0
6	595.0	598.0
Red Orange		
1	611.0	616.0
2	616.0	620.0
3	620.0	625.0
Red		
Full Distribution	620.0	635.0

Tolerance of each bin limit = ± 1nm

V_f Binning for All InGaP Devices (ASMT-QAxx/QHxx/QRxx)

Bin ID	Min.	Max.
2D	2.35	2.50
2E	2.50	2.65
2F	2.65	2.80
2G	2.80	2.95
2H	2.95	3.10
2J	3.10	3.25
2K	3.25	3.40
2L	3.40	3.55
2M	3.55	3.70
2N	3.70	3.85

Tolerance of each bin limit = ± 0.1V

V_f Bin Limits for InGaN Devices (ASMT-QBxx/QGxx)

Bin ID	Min.	Max.
S5	3.20	3.50
S6	3.50	3.80
S7	3.80	4.10

Tolerance of each bin limit = ± 0.1V

Packaging Option (X₅)

X ₅	Test Current)	Package Type	Reel Size
E	150 mA	Top Mount	7 inch

LED Solutions

Super 0.5W White Power PLCC-4

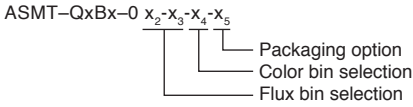

Flux Bin Selection (X_2, X_3)

Individual reel will contain parts from one bin only

X_2	Min Flux Bin
X_3	Min Flux Bin

Flux Bin Limits

Bin ID	Min. (lm)	Max. (lm)
O	3.40	4.30
A	4.30	5.50
B	5.50	7.00
C	7.00	9.00
D	9.00	11.50
E	11.50	15.00
F	15.00	19.50
G	19.50	25.50
H	25.50	33.00
J	33.00	43.00
K	43.00	56.00
L	56.00	73.00

Tolerance of each bin limit = $\pm 12\%$

Color Bin Selection (X_4) for ASMT-QWBx

Individual reel will contain parts from one sub bin only.

X_4	
O	Full Distribution
A	5K and 5L only
B	6K and 6L only
C	7K and 7L only
D	8K and 8L only
E	5K and 6K only
F	5L and 6L only
G	6K and 7K only
H	6L and 7L only
J	7K and 8K only
K	7L and 8L only
L	5K, 5L, 6K and 6L only
M	6K, 6L, 7K and 7L only
N	7K, 7L, 8K and 8L only
Z	Special binning

Color Bin Limits for ASMT-QWBx

Bin ID	Sub Bin ID	Limits (Chromaticity Coordinates)				
5K	5Ka	x	0.296	0.304	0.302	0.294
		y	0.259	0.270	0.276	0.264
	5Kb	x	0.294	0.302	0.300	0.291
		y	0.264	0.276	0.281	0.268
	5Kc	x	0.304	0.313	0.312	0.302
		y	0.270	0.284	0.291	0.276
	5Kd	x	0.302	0.312	0.310	0.300
		y	0.276	0.291	0.297	0.281
5L	5La	x	0.291	0.300	0.298	0.288
		y	0.268	0.281	0.288	0.274
	5Lb	x	0.288	0.298	0.295	0.285
		y	0.274	0.288	0.294	0.279
	5Lc	x	0.300	0.310	0.309	0.298
		y	0.281	0.297	0.305	0.288
	5Ld	x	0.298	0.309	0.307	0.295
		y	0.288	0.305	0.312	0.294
6K	6Ka	x	0.313	0.322	0.321	0.312
		y	0.284	0.297	0.305	0.291
	6Kb	x	0.312	0.321	0.320	0.310
		y	0.291	0.305	0.314	0.297
	6Kc	x	0.322	0.330	0.330	0.321
		y	0.297	0.310	0.320	0.305
	6Kd	x	0.321	0.330	0.330	0.320
		y	0.305	0.320	0.330	0.314

Tolerance of each bin limit = ± 0.02 .

Color Bin Limits cont.

Bin ID	Sub Bin ID	Limits (Chromaticity Coordinates)				
6L	6La	x	0.310	0.320	0.319	0.309
		y	0.297	0.314	0.322	0.305
	6Lb	x	0.309	0.319	0.318	0.307
		y	0.305	0.322	0.329	0.312
	6Lc	x	0.320	0.330	0.330	0.319
		y	0.314	0.330	0.339	0.322
	6Ld	x	0.319	0.330	0.330	0.318
		y	0.322	0.339	0.347	0.329
7K	7Ka	x	0.330	0.336	0.337	0.330
		y	0.310	0.320	0.330	0.320
	7Kb	x	0.330	0.337	0.337	0.330
		y	0.320	0.330	0.341	0.330
	7Kc	x	0.336	0.343	0.344	0.337
		y	0.320	0.331	0.341	0.330
	7Kd	x	0.337	0.344	0.345	0.337
		y	0.330	0.341	0.352	0.341
7L	7La	x	0.330	0.337	0.337	0.330
		y	0.330	0.341	0.349	0.339
	7Lb	x	0.330	0.337	0.338	0.330
		y	0.339	0.349	0.358	0.347
	7Lc	x	0.337	0.345	0.346	0.337
		y	0.341	0.352	0.362	0.349
	7Ld	x	0.337	0.346	0.347	0.338
		y	0.349	0.362	0.371	0.358
8K	8Ka	x	0.343	0.351	0.352	0.344
		y	0.331	0.343	0.354	0.341
	8Kb	x	0.344	0.352	0.354	0.345
		y	0.341	0.354	0.364	0.352
	8Kc	x	0.351	0.360	0.362	0.352
		y	0.343	0.357	0.369	0.354
	8Kd	x	0.352	0.362	0.364	0.354
		y	0.354	0.369	0.380	0.364
8L	8La	x	0.345	0.354	0.355	0.346
		y	0.352	0.364	0.375	0.362
	8Lb	x	0.346	0.355	0.356	0.347
		y	0.362	0.375	0.385	0.371
	8Lc	x	0.354	0.364	0.366	0.355
		y	0.364	0.380	0.391	0.375
	8Ld	x	0.355	0.366	0.367	0.356
		y	0.375	0.391	0.401	0.385

Tolerance of each bin limit = ± 0.02 .

LED Solutions

Color Coordinates Chart for ASMT-QWBx

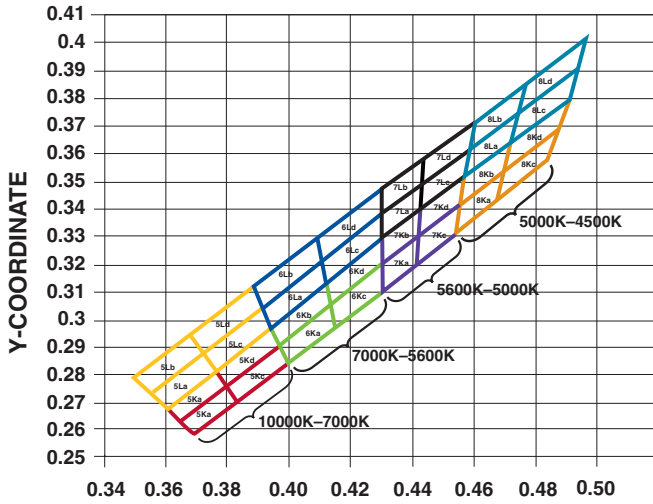

Color Coordinates Chart for ASMT-QYBx

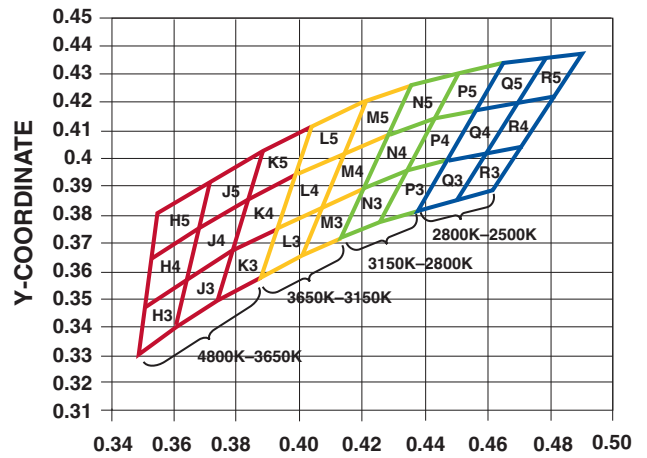

Color Bin Selection (X₄) for ASMT-QYBx

Individual reel will contain parts from one sub bin only.

X ₄	Description
0	Full Distribution
A	H, J and K only
B	H, J, K, L and M only
C	L and M only
D	L, M, N and P only
E	N and P only
F	N, P, Q and R only
G	Q and R only
Z	Special Color Bin

Color Bin Limits for ASMT-QYBx

Bin ID	Sub Bin ID	Limits (Chromaticity Coordinates)				
L	L3	x	0.387	0.400	0.407	0.393
		y	0.358	0.366	0.384	0.376
	L4	x	0.393	0.407	0.414	0.399
		y	0.376	0.384	0.402	0.395
	L5	x	0.399	0.414	0.421	0.405
		y	0.395	0.402	0.420	0.412
M	M3	x	0.400	0.413	0.421	0.407
		y	0.366	0.372	0.390	0.384
	M4	x	0.407	0.421	0.429	0.414
		y	0.384	0.390	0.409	0.402
	M5	x	0.414	0.429	0.436	0.421
		y	0.402	0.409	0.426	0.420
N	N3	x	0.413	0.425	0.434	0.421
		y	0.372	0.378	0.396	0.390
	N4	x	0.421	0.434	0.443	0.429
		y	0.390	0.396	0.414	0.409
	N5	x	0.429	0.443	0.451	0.436
		y	0.409	0.414	0.430	0.426
P	P3	x	0.425	0.438	0.447	0.434
		y	0.378	0.382	0.400	0.396
	P4	x	0.434	0.447	0.456	0.443
		y	0.396	0.400	0.417	0.414
	P5	x	0.443	0.456	0.465	0.451
		y	0.414	0.417	0.434	0.430
Q	Q3	x	0.438	0.450	0.460	0.447
		y	0.382	0.386	0.403	0.400
	Q4	x	0.447	0.460	0.470	0.456
		y	0.400	0.403	0.420	0.417
	Q5	x	0.456	0.470	0.479	0.465
		y	0.417	0.420	0.436	0.434

Color Bin Limits for ASMT-QYBx

Bin ID	Sub Bin ID	Limits (Chromaticity Coordinates)				
R	R3	x	0.450	0.462	0.472	0.460
		y	0.386	0.389	0.405	0.403
	R4	x	0.460	0.472	0.482	0.470
		y	0.403	0.405	0.422	0.420
	R5	x	0.470	0.482	0.491	0.479
		y	0.420	0.422	0.437	0.436

Tolerance of each bin limit = ± 0.02

Color Bin Limits for ASMT-QYBx

Bin ID	Sub Bin ID	Limits (Chromaticity Coordinates)				
H	H3	x	0.348	0.360	0.364	0.350
		y	0.332	0.341	0.358	0.348
	H4	x	0.350	0.364	0.367	0.352
		y	0.348	0.358	0.376	0.365
	H5	x	0.352	0.367	0.371	0.354
		y	0.365	0.376	0.392	0.381
J	J3	x	0.360	0.373	0.378	0.364
		y	0.341	0.350	0.368	0.358
	J4	x	0.364	0.378	0.383	0.367
		y	0.358	0.368	0.386	0.376
	J5	x	0.367	0.383	0.388	0.371
		y	0.376	0.386	0.403	0.392
K	K3	x	0.373	0.387	0.393	0.378
		y	0.350	0.358	0.376	0.368
	K4	x	0.378	0.393	0.399	0.383
		y	0.368	0.376	0.395	0.386
	K5	x	0.383	0.399	0.405	0.388
		y	0.386	0.395	0.412	0.403

Packaging Option (X₅)

X ₅	Test Current	Package Type	Reel Size
E	150 mA	Top Mount	7 inch

LED Solutions

Package Dimensions

PLCC-2 Top Mount

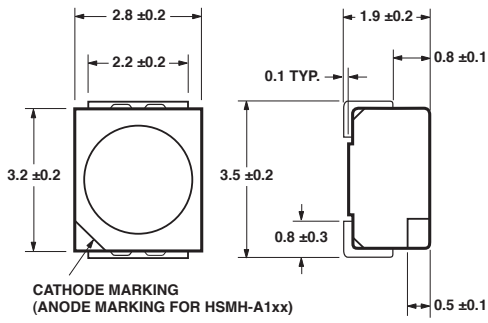

PLCC-2 Reverse Mount

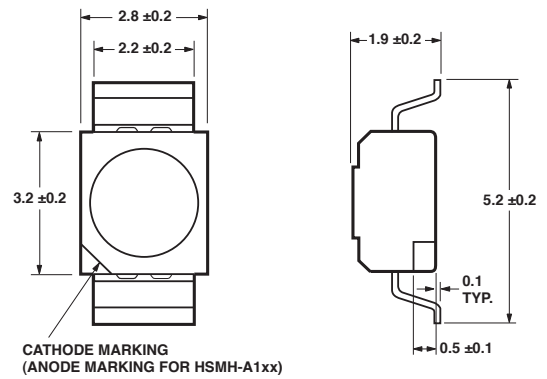

Power PLCC-4 with Lens

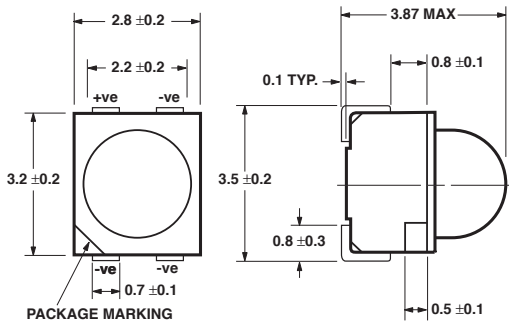

BiColor/TriColor PLCC4/Power PLCC-4

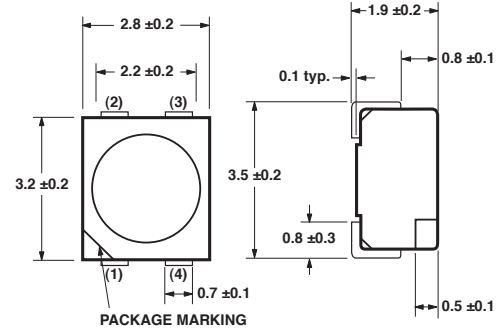

Super 0.5W Power PLCC-4

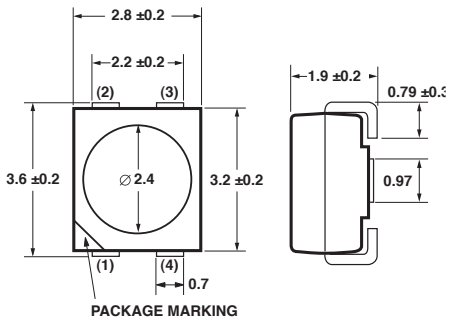

High Brightness Tricolor PLCC-4

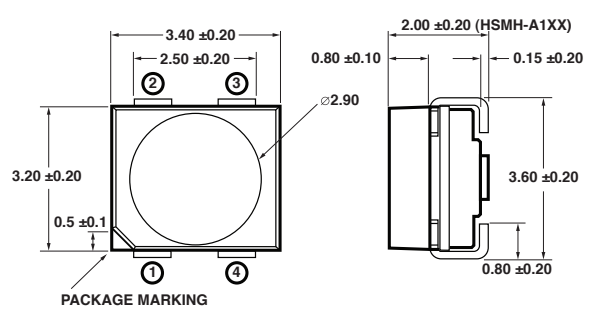

High Brightness Tricolor PLCC-6

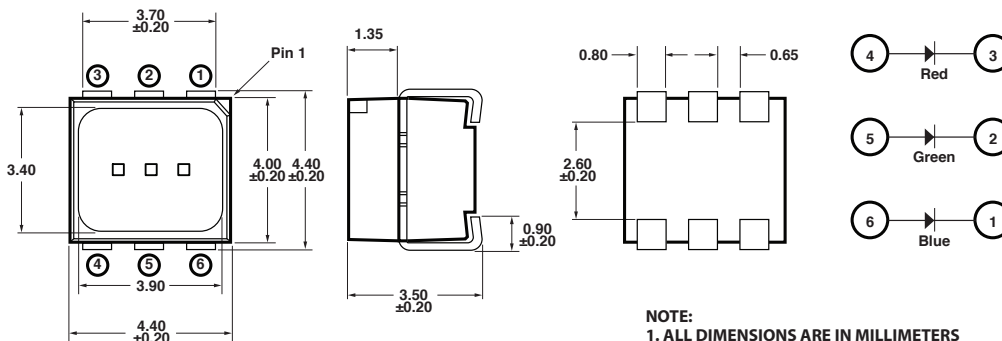

NOTE:
1. ALL DIMENSIONS ARE IN MILLIMETERS



Envisium™ Power PLCC-4 Surface Mount LEDs

Description

Envisium™ is the premier class of mid-Power LEDs using TS AllnGaP chip technology. Envisium™ LEDs offer unparalleled performance, engineering and design flexibility.

Envisium™ Power PLCC-4 SMT LEDs, available in red, red-orange and amber, fill the need for mid-power illumination capabilities between Avago Technologies' conventional PLCC-4 products, and the Super 0.5W Power PLCC-4. The Power PLCC-4 package can be driven at high current due to its superior design, and is able to dissipate the heat more efficiently than conventional PLCC-2 SMT LEDs. It also offers much higher quality and reliability and superior mechanical characteristics to reduce tombstoning, prevent delamination and improve pick-and-place assembly.

The reliability and performance characteristics of these mid-power LEDs, such as their -40°C to +100°C operating temperature range, make them uniquely suitable for use in harsh conditions such as automotive applications, and in electronic signs and signals. To facilitate easy pick and place assembly, the LEDs are packed in EIA-compliant tape and reel. Every reel is shipped in single intensity and color bin (except for red) to provide close uniformity.

These LEDs are compatible with both IR solder reflow and through-the-wave (TTW) soldering processes.

Features and Benefits

- Industry Standard PLCC-4 (plastic leaded chip carrier) form factor
- High reliability Power PLCC-4 package
- High brightness with optimum flux performance using TS AllnGaP dice technologies
- Available in red, red orange and amber colors
- High optical efficiency
- Higher ambient temperature at the same current possible compared to PLCC-2
- Super wide 120-degree viewing angle
- Well-suited for backlighting applications
- Supplied in EIA-standard 8 mm carrier tape on 7 inch reel
- Compatible with both IR and TTW soldering processes

Applications

- Interior automotive
 - Instrument panel backlighting
 - Central console backlighting
 - Navigation and audio system lighting
 - Push button backlighting
- Exterior automotive
 - Turn signals
 - Side repeater lamps
 - CHMSLs (center high-mounted stop light)
 - Rear combination lamps
 - Puddle lights
- Electronic signs and signals
 - Channel lettering
 - Contour lighting
 - Indoor variable message signs
- Office automation, home appliances, industrial equipment
 - Front panel backlighting
 - Push button backlighting
 - Display backlighting

LED Solutions

Device Selection Guide

Envisium 0.25W Power PLCC-4 Surface Mount LED

Part Number	Color	Typ. Dominant Wavelength λ_D (nm) ¹	Typ. Viewing Angle $2\theta_{1/2}$ (°) ²	Intensity Bin	Min. IV (mcd)	Max. IV (mcd)	Total Flux Φ_V (mlm) ^{4,5} Typ.	Typ. Vf (V)	Test Current (mA)
ASMC-PRB9-TV005	AllnGaP Red	630.0	120	V1	630.00	1000.00	2600.00	2.8	50
		630.0	120	V2	790.00	1260.00	3300.00	2.8	50
		630.0	120	W1	1000.00	1600.00	–	2.8	50
ASMC-PHB9-TW005	AllnGaP Red Orange	617.0	120	W1	1000.00	1600.00	4300.00	2.8	50
		617.0	120	W2	1200.00	2020.00	5000.00	2.8	50
		617.0	120	X1	1580.00	2500.00	–	2.8	50
ASMC-PAB9-TV005	AllnGaP Amber	592.0	120	V1	630.00	1000.00	3000.00	2.8	50
		592.0	120	V2	790.00	1260.00	3800.00	2.8	50
		592.0	120	W1	1000.00	1600.00	–	2.8	50

Notes:

1. The dominant wavelength, λ_D , is derived from the CIE Chromaticity Diagram and represents the color of the device.
2. $\theta_{1/2}$ is the off-axis angle where the luminous intensity is 1/2 the peak intensity.
3. The luminous intensity, I_v , is measured at the mechanical axis of the lamp package. The actual peak of the spatial radiation pattern may not be aligned with this axis.
4. Φ is the total luminous flux output as measured with an integrating sphere at mono pulse conditions.

Envisium 0.5W Power PLCC-4 Surface Mount LED

Part Number	Color	Typ. Dominant Wavelength λ_D (nm) ¹	Typ. Viewing Angle $2\theta_{1/2}$ (°) ²	Flux Bin	Min. Flux (lm)	Max. Flux (lm)	Typ. Vf (V)	Test Current (mA)	Dice Technology
ASMC-QAB2-TACOE	Amber	593.5	120	A	4.3	5.5	2.64	150	AllnGaP
				B	5.5	7.0		150	
				C	7.0	9.0		150	
ASMC-QHB2-TCDOE	Red Orange	619.3	120	C	7.0	9.0	2.64	150	AllnGaP
				D	9.0	11.5		150	

Notes:

1. The dominant wavelength, λ_D , is derived from the CIE Chromaticity Diagram and represents the color of the device.
2. $\theta_{1/2}$ is the off-axis angle where the luminous intensity is 1/2 the peak intensity.
3. The luminous intensity, I_v , is measured at the mechanical axis of the lamp package. The actual peak of the spatial radiation pattern may not be aligned with this axis.
4. Φ is the total luminous flux output as measured with an integrating sphere at mono pulse conditions.

Envisium 0.25W Power PLCC-4

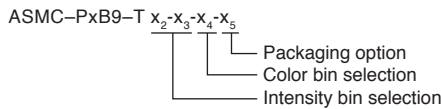

Intensity Bin Selection (X_2, X_3)

X_2	Min. I_v Bin
X_3	Number of half bins
0	Full Distribution
2	2 half bins starting from $X_{2,1}$
3	3 half bins starting from $X_{2,1}$
4	4 half bins starting from $X_{2,1}$
5	5 half bins starting from $X_{2,1}$
6	2 half bins starting from $X_{2,2}$
7	3 half bins starting from $X_{2,2}$
8	4 half bins starting from $X_{2,2}$
9	5 half bins starting from $X_{2,2}$

Intensity Bin Limits

Bin ID	Min. (mcd)	Max. (mcd)
V1	715.00	900.00
V2	900.00	1125.00
W1	1125.00	1400.00
W2	1400.00	1800.00
X1	1800.00	2240.00
X2	2240.00	2850.00

Tolerance of each bin limit = $\pm 12\%$

LED Solutions

Package Dimensions

Envisium 0.25W Power PLCC-4

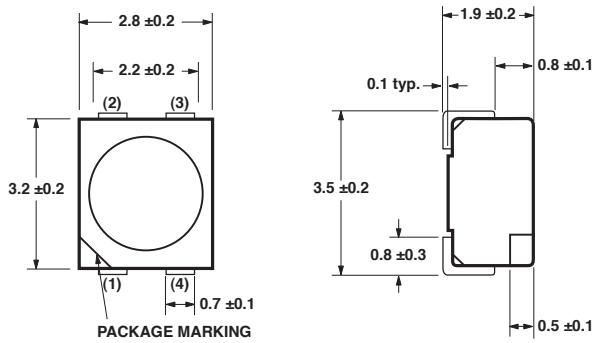

Note: All dimensions in mm

Envisium Power PLCC-4	
1	Cathode
2	Anode
3	Cathode
4	Cathode

Envisium 0.5W Power PLCC-4

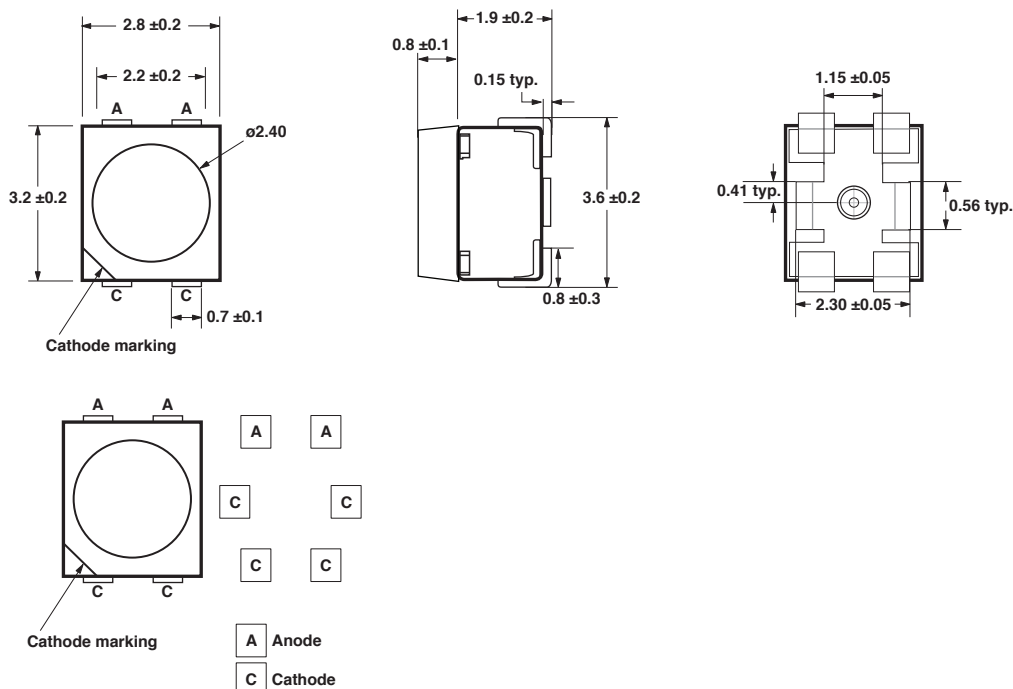

Envisium Power PLCC-4 LEDs

Moonstone™ High Power LEDs

Description

High Power LED is a high-performance, energy-efficient device that can handle high-thermal and high-driving current. The exposed pad design has excellent heat transfer from the package to the motherboard. The low-profile package design is suitable for a wide variety of applications, especially where height is a constraint. The package is compatible with the SMT reflow soldering process. This will give more freedom and flexibility to the light source designer.

Features and Benefits

- Available in White, Blue, Green, Red and Amber color
- Energy efficient
- Exposed pad for excellent heat transfer
- Suitable for SMT process
- High-current operation
- Long operation life
- Wide viewing angle
- Silicone encapsulation
- Available in emitter and module

Typical Applications

- Portable (flashlight, bicycle headlight)
- Reading light
- Architectural lighting
- Garden lighting
- Decorative lighting
- Street lighting
- Retail lighting
- Contour lighting
- Sign backlighting

Specifications

- InGaN: 4.0 V (max) at 350 mA
4.3 V (max) at 700 mA
- AllInGaP: 3.0 V (max) at 350 mA
- Viewing angle of 120° and 110°

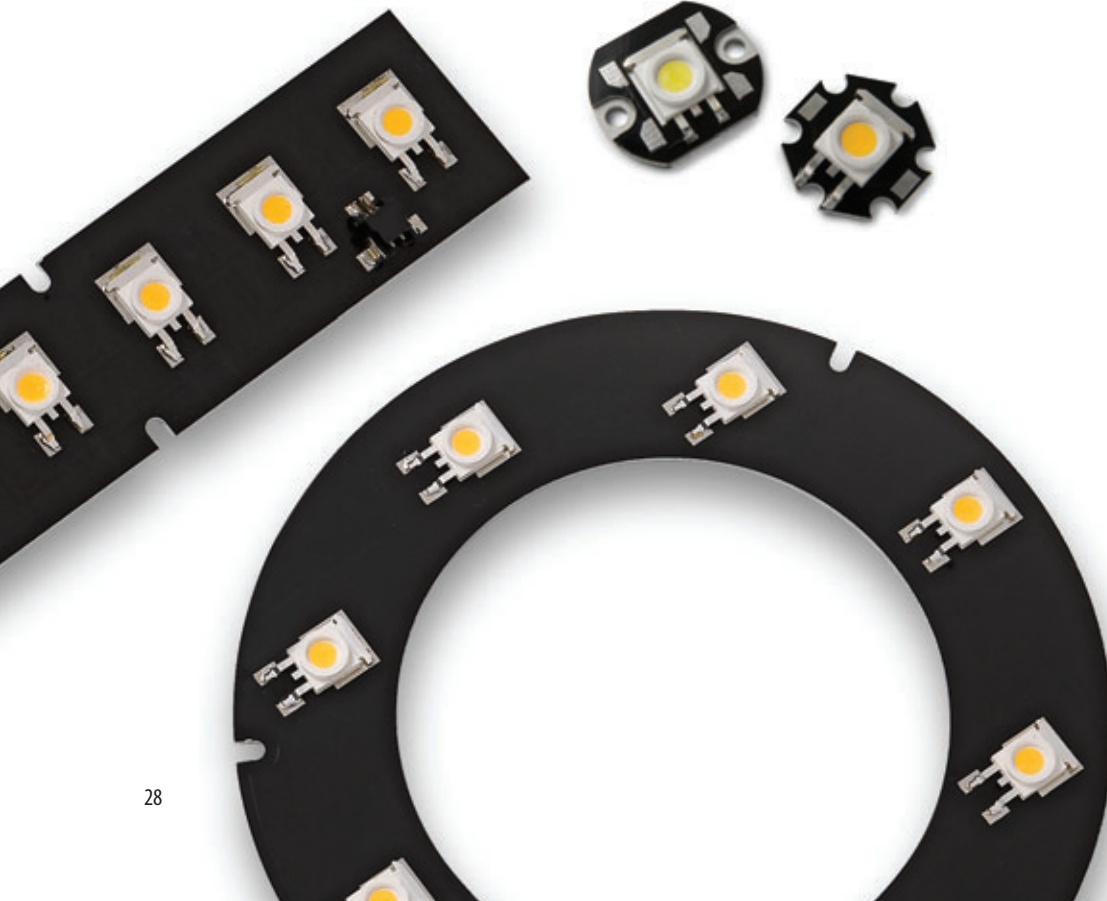

LED Solutions

Moonstone™ 0.5W White LEDs

Part Number	Color	Encapsulation Type	Forward voltage (V)	Viewing Angle (°)	Color Temperature (0K)	Test Current (mA)	Flux (lm) @ 150mA			Heatsink
							Min.	Typ.	Max.	
ASMT-MW60-NFH00	InGaN Cool White	Clear	3.5	110	4,000K - 10,000K	150	19.5	30	43	Non-electrically isolated
ASMT-MW62-NFH00	InGaN Cool White	Clear	3.5	110	4,000K - 10,000K	150	19.5	30	43	Electrically isolated
ASMT-MWH0-NFH00	InGaN Cool White	Diffused	3.5	120	4,000K - 10,000K	150	15	25	43	Non-electrically isolated
ASMT-MWH2-NFH00	InGaN Cool White	Diffused	3.5	120	4,000K - 10,000K	150	15	25	43	Electrically isolated
ASMT-MY60-NEG00	InGaN Warm White	Clear	3.5	110	2,600K - 4,000K	150	15	25	33	Non-electrically isolated
ASMT-MY62-NEG00	InGaN Warm White	Clear	3.5	110	2,600K - 4,000K	150	15	25	33	Electrically isolated
ASMT-MYH0-NEG00	InGaN Warm White	Diffused	3.5	120	2,600K - 4,000K	150	15	20	33	Non-electrically isolated
ASMT-MYH2-NEG00	InGaN Warm White	Diffused	3.5	120	2,600K - 4,000K	150	15	20	33	Electrically isolated

* = for enhanced uniformity, Avago recommends diffused versions if the application uses secondary optics

Moonstone™ 1W LEDs

Part Number	Color	Encapsulation Type	Forward voltage (V)	Viewing Angle (°)	Wavelength / (nm)	Test Current (mA)	Flux (lm) @ 350mA			Heatsink
							Min.	Typ.	Max.	
ASMT-MB00-NDF00	InGaN Blue	Clear	3.6	110	467	350	11.5	15	25.5	Electrically isolated
ASMT-MG00-NJK00	InGaN Green	Clear	3.6	110	525	350	43	60	73	Electrically isolated
ASMT-MA00-AGH00	AllInGaP Amber	Clear	2.4	110	590	350	25.5	35	43	Non-electrically isolated
ASMT-MR00-AGH00	AllInGaP Red	Clear	2.4	110	625	350	25.5	35	43	Non-electrically isolated
ASMT-MR00-AHJ00	AllInGaP Red	Clear	2.4	110	625	350	33	40	56	Non-electrically isolated

LED Solutions

Moonstone™ 1W White LEDs

Part Number	Color	Encapsulation Type	Forward voltage (V)	Viewing Angle (°)	Color Temperature (0K)	Test Current (mA)	Flux (lm) @ 350mA			Heatsink
							Min.	Typ.	Max.	
ASMT-MW09-NMM00	InGaN Cool White	Clear	3.6	120	4,000-10,000K	350	95	-	124	Non-electrically isolated
ASMT-MWB9-NLM00	InGaN Cool White	Diffused	3.6	120	4,000-10,000K	350	73	95	124	Non-electrically isolated
ASMT-MW09-NLL00	InGaN Cool White	Clear	3.6	120	4,000-10,000K	350	73	80	95	Non-electrically isolated
ASMT-MWB9-NKL00	InGaN Cool White	Diffused	3.6	120	4,000-10,000K	350	56	73	95	Electrically isolated
ASMT-MW05-NLL00	InGaN Cool White	Clear	3.6	110	4,000-10,000K	350	73	80	95	Non-electrically isolated
ASMT-MW06-NLL00	InGaN Cool White	Clear	3.6	110	4,000-10,000K	350	73	80	95	Electrically isolated
ASMT-MWB5-NKL00	InGaN Cool White	Diffused	3.6	120	4,000-10,000K	350	56	73	95	Non-electrically isolated
ASMT-MWB6-NKL00	InGaN Cool White	Diffused	3.6	120	4,000-10,000K	350	56	73	95	Electrically isolated
ASMT-MW03-NJK00	InGaN Cool White	Clear	3.5	110	4,000-10,000K	350	43	55	73	Non-electrically isolated
ASMT-MW04-NJK00	InGaN Cool White	Clear	3.5	110	4,000-10,000K	350	43	55	73	Electrically isolated
ASMT-MWB3-NHK00	InGaN Cool White	Diffused	3.5	120	4,000-10,000K	350	33	50	73	Non-electrically isolated
ASMT-MWB4-NHK00	InGaN Cool White	Diffused	3.5	120	4,000-10,000K	350	33	50	73	Electrically isolated
ASMT-MY09-NLM00	InGaN Warm White	Diffused	3.6	120	2,600-4000K	350	73		124	Non-electrically isolated
ASMT-MYB9-NLM00	InGaN Warm White	Diffused	3.6	120	2,600-4000K	350	73		124	Non-electrically isolated
ASMT-MY09-NKL00	InGaN Warm White	Clear	3.6	120	2,600-4000K	350	56	73	95	Non-electrically isolated
ASMT-MYB9-NKL00	InGaN Warm White	Diffused	3.6	120	2,600-4000K	350	56	68	95	Electrically isolated
ASMT-MY05-NKL00	InGaN Warm White	Clear	3.6	110	2,600-4,000K	350	56	73	95	Non-electrically isolated
ASMT-MY06-NKL00	InGaN Warm White	Clear	3.6	110	2,600-4,000K	350	56	73	95	Non-electrically isolated
ASMT-MYB5-NKL00	InGaN Warm White	Diffused	3.6	110	2,600-4,000K	350	56	65	95	Non-electrically isolated
ASMT-MYB6-NKL00	InGaN Warm White	Diffused	3.6	110	2,600-4,000K	350	56	65	95	Electrically isolated
ASMT-MY03-NJK00	InGaN Warm White	Clear	3.6	110	2,600-4,000K	350	43	50	73	Non-electrically isolated
ASMT-MY04-NJK00	InGaN Warm White	Clear	3.6	110	2,600-4,000K	350	43	50	73	Electrically isolated
ASMT-MYB3-NHK00	InGaN Warm White	Diffused	3.6	110	2,600-4,000K	350	33	45	73	Non-electrically isolated
ASMT-MYB4-NHK00	InGaN Warm White	Diffused	3.6	110	2,600-4,000K	350	33	45	73	Electrically isolated

* = for enhanced uniformity, Avago recommends diffused versions if the application uses secondary optics

LED Solutions

Moonstone™ 3W White LEDs

Part Number	Color	Encapsulation Type	Forward voltage (V)	Viewing Angle (°)	Color Temperature (0K)	Test Current (mA)	Flux (lm) @ 350mA			Heatsink
							Min.	Typ.	Max.	
ASMT-MW20-NNN00	InGaN Cool White	Clear	4.0	120	4,000-10,000K	700	124	145	161	Non-electrically isolated
ASMT-MW22-NNN00	InGaN Cool White	Clear	4.0	120	4,000-10,000K	700	124	145	161	Electrically isolated
ASMT-MWE0-NMN00	InGaN Cool White	Clear	4.0	120	4,000-10,000K	700	95	125	161	Non-electrically isolated
ASMT-MWE2-NMN00	InGaN Cool White	Clear	4.0	120	4,000-10,000K	700	95	125	161	Electrically isolated
ASMT-MY20-NMN00	InGaN Warm White	Diffused	4.0	120	2,600-4,000K	700	95	125	161	Non-electrically isolated
ASMT-MY22-NMN00	InGaN Warm White	Diffused	4.0	120	2,600-4,000K	700	95	125	161	Electrically isolated
ASMT-MYE0-NMN00	InGaN Warm White	Diffused	4.0	120	2,600-4,000K	700	95	110	161	Non-electrically isolated
ASMT-MYE2-NMN00	InGaN Warm White	Diffused	4.0	120	2,600-4,000K	700	95	110	161	Electrically isolated

* = for enhanced uniformity, Avago recommends diffused versions if the application uses secondary optics

Moonstone™ 3W RGB Tricolor LEDs

Part Number	Color	Encapsulation Type	Forward voltage (V)	Viewing Angle (°)	Wavelength / (nm)	Test Current (mA)	Flux (lm) @ 350mA			Heatsink
							Min.	Typ.	Max.	
ASMT-MT00-00001	AllInGaP Red	Clear	2.4	120	620-635	350	33	40	56	Non-electrically isolated
	InGaN Green	Clear	3.5	120	515-535	350	43	55	95	Non-electrically isolated
	InGaN Blue	Clear	3.5	120	460-480	350	9	13	19.5	Non-electrically isolated

1W Moonstone™ 1W LED Module

Part Number	Color	Number of LEDs	Power (W)	Module Type	Color Temperature (K)	Viewing Angle (°)	Luminous Flux, Φ _v (lm)			Forward Voltage (V)	Test Current (mA)	Driving Method
							Min.	Typ.	Max.			
ASMT-MAAO-AGH00	AllInGaP Amber	1	1	Star I	590	120	25.5	35	43	2.4	350	Current/Voltage
ASMT-MRAO-AGH00	AllInGaP Red	1	1	Star I	625	120	56	35	43	2.4	350	Current/Voltage
ASMT-MRAO-AHJ00	AllInGaP Red	1	1	Star I	625	120	33	40	56	2.4	350	Current/Voltage
ASMT-MBAO-NDF00	InGaN Blue	1	1	Star I	467	120	11.5	15	25.5	3.6	350	Current/Voltage
ASMT-MGAO-NJK00	InGaN Green	1	1	Star I	525	120	43	55	73	3.6	350	Current/Voltage
ASMT-MAKO-AGH00	AllInGaP Amber	1	1	Star II	590	120	25.5	35	43	2.4	350	Current/Voltage
ASMT-MRKO-AGH00	AllInGaP Red	1	1	Star II	625	120	56	35	43	2.4	350	Current/Voltage
ASMT-MRKO-AHJ00	AllInGaP Red	1	1	Star II	625	120	33	40	56	2.4	350	Current/Voltage
ASMT-MBKO-NDF00	InGaN Blue	1	1	Star II	467	120	11.5	15	25.5	3.6	350	Current/Voltage
ASMT-MGKO-NJK00	InGaN Green	1	1	Star II	525	120	43	55	73	3.6	350	Current/Voltage

LED Solutions

Moonstone™ 1W White LED Module

Part Number	Color	Number of LEDs	Power (W)	Module Type	Color Temperature (K)	Viewing Angle 2q½ (°)	Luminous Flux, Φ _v (lm)			Forward Voltage (V)	Test Current (mA)	Driving Method
							Min.	Typ.	Max.			
ASMT-MWA0-NKK00	InGaN Cool White	1	1	Star I	4000-10000	110	56	60	73	3.6	350	Current/Voltage
ASMT-MYA0-NJK00	InGaN Warm White	1	1	Star I	2600-4000	110	43	50	73	3.6	350	Current/Voltage
ASMT-MWK0-NKK00	InGaN Cool White	1	1	Star II	4000-10000	110	56	60	73	3.6	350	Current/Voltage
ASMT-MYK0-NJK00	InGaN Warm White	1	1	Star II	2600-4000	110	43	50	73	3.6	350	Current/Voltage
ASMT-MWK5-NLLO0	InGaN Cool White	1	1	Star II	4000-10000	110	73	80	95	3.6	350	Current/Voltage
ASMT-MYK5-NKLO0	InGaN Warm White	1	1	Star II	2600-4000	110	56	73	92	3.6	350	Current/Voltage
ASMT-MWK9-NLLO0	InGaN Cool White	1	1	Star II	4000-10000	120	73	80	73	3.6	350	Current/Voltage
ASMT-MYK9-NKLO0	InGaN Warm White	1	1	Star II	2600-4000	120	56	73	73	3.6	350	Current/Voltage
ASMT-MWK9-NMM00	InGaN Cool White	1	1	Star II	4000-10000	120	95	-	124	3.6	350	Current/Voltage
ASMT-MYK9-NLM00	InGaN Warm White	1	1	Star II	2600-4000	120	73	95	124	3.6	350	Current/Voltage
ADJD-WM00-NKKZ0	InGaN Cool White	3	4	Strip	4500-5600K			180			350	Current
ADJD-WM01-NKKZ0	InGaN Cool White	3	4	Strip	4500-5600K			180		12		Voltage
ADJD-YM00-NJJZ0	InGaN Warm White	3	4	Strip	2600-3000K			150			350	Current
ADJD-YM01-NJJZ0	InGaN Warm White	3	4	Strip	2600-3000K			150		12		Voltage
ADJD-WM10-NKKZ0	InGaN Cool White	4	5	Strip	4500-5600K			240			350	Current
ADJD-YM10-NJJZ0	InGaN Warm White	4	5	Strip	2600-3000K			200			350	Current
ADJD-WM21-NKKZ0	InGaN Cool White	6	8	Strip	4500-5600K			360		12		Voltage
ADJD-YM21-NJJZ0	InGaN Warm White	6	8	Strip	2600-3000K			300		12		Voltage
ADJD-WM00-NKKZ0	InGaN Cool White	7	9	Round	4500-5600K			420			350	Current
ADJD-YM00-NJJZ0	InGaN Warm White	7	9	Round	2600-3000K			350			350	Current
ADJD-YMR3-NKKZ0	InGaN Cool White	8	10	Ring	4500-5600K			480			700	Current
ADJD-YMR3-NJJZ0	InGaN Warm White	8	10	Ring	2600-3000K			400			700	Current
ADJD-WM30-NKKZ0	InGaN Cool White	9	12	Strip	4500-5600K			540			1050	Current
ADJD-YM30-NJJZ0	InGaN Warm White	9	12	Strip	2600-3000K			450			1050	Current
ADJD-WM40-NKKZ0	InGaN Cool White	12	15	Strip	4500-5600K			720			700	Current
ADJD-YM40-NJJZ0	InGaN Warm White	12	15	Strip	2600-3000K			600			700	Current

Package Dimensions Moonstone LED Emitters

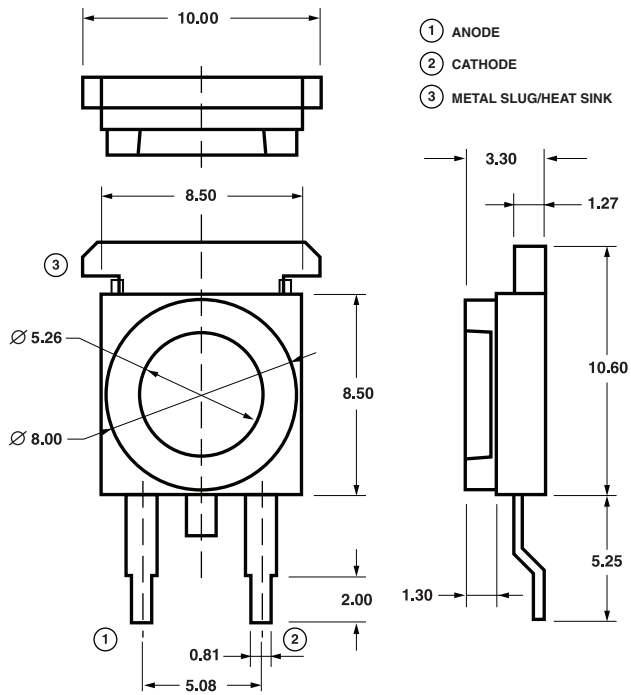

Notes:

1. All Dimensions in millimeters.
2. Tolerance is ± 0.1 mm unless otherwise specified.
3. Metal slug is connected to anode for electrically non-isolated option.

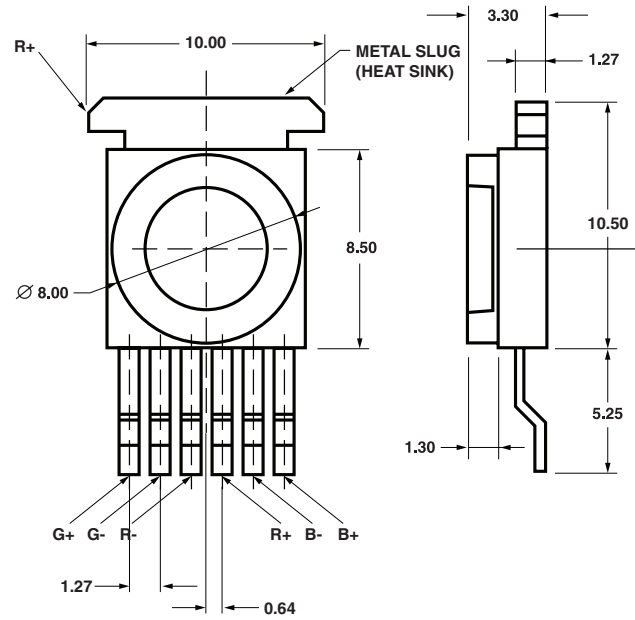

Notes:

1. All dimensions in millimeters.
2. Tolerance is ± 0.1 mm unless otherwise specified.
3. Metal slug is connected to the anode of Red.

LED Solutions

Package Dimensions Moonstone LED Light Strips

ADJD-xM00 (3 LEDs)

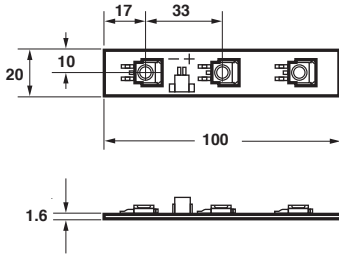

ADJD-xM30 (9 LEDs)

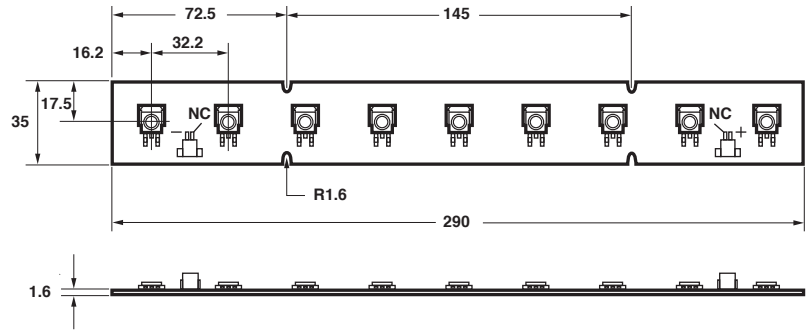

ADJD-xM01 (3 LEDs)

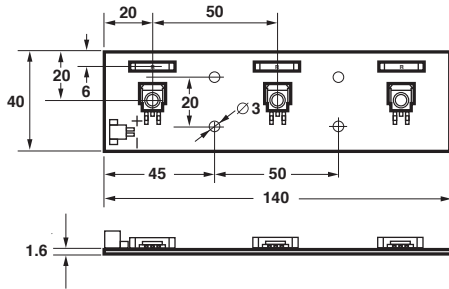

ADJD-xM40 (12 LEDs)

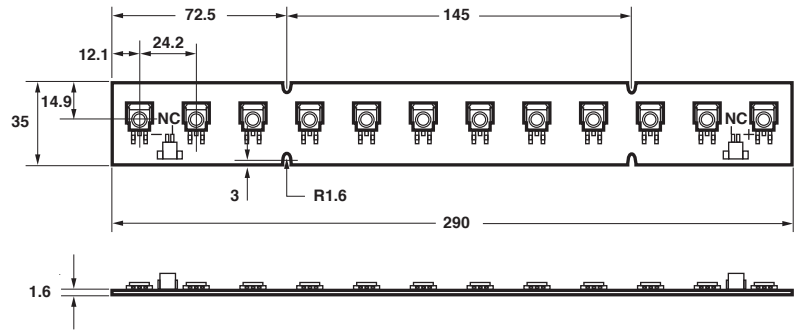

ADJD-xM10 (4 LEDs)

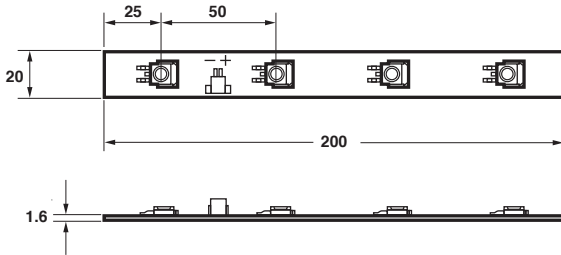

ADJD-xM21 (6 LEDs)

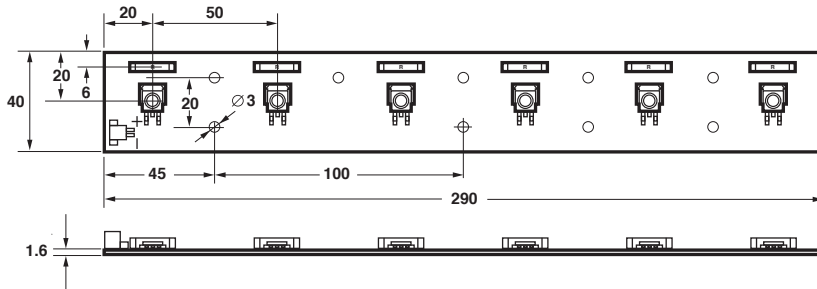

NOTES:
ALL DIMENSIONS IN MILLIMETERS
TOLERANCE IS $\pm 0.1\text{MM}$ UNLESS OTHERWISE SPECIFIED

LED Solutions

Package Dimensions Moonstone LED Light Strips

ADJD-xMR0 (7 LEDs)

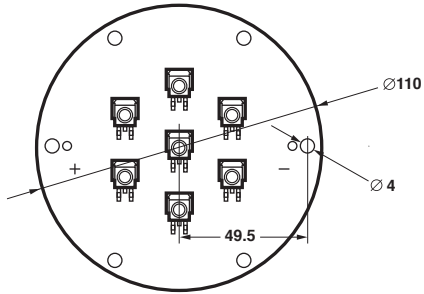

ADJD-xMR3 (8 LEDs)

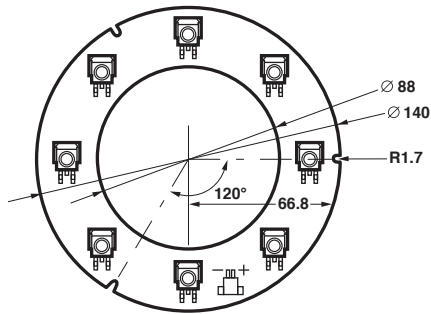

Moonstone Star I LED Modules

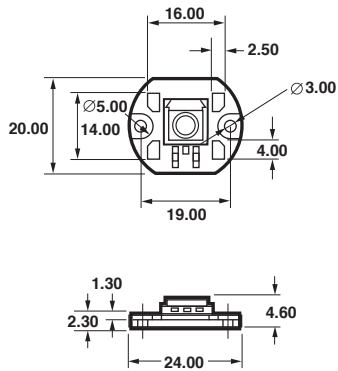

Moonstone Star II LED Modules

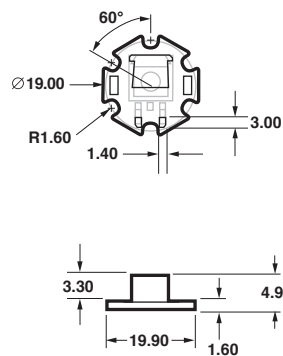

NOTES:
DIMENSIONS IN MILLIMETERS
TOLERANCE IS ± 0.1 MM UNLESS OTHERWISE SPECIFIED

High Power LEDs

Description

Avago High Power and Mini High Power LED is a high performance, energy efficient device which can handle high thermal and high driving current. The White High Power LED is available in the range of color temperature from 2700K to 10000K.

The low profile package design and ultra small footprint is suitable for a wide variety of applications especially where space and height is a constraint.

The package is compatible with reflow soldering process. It is packed in EIA-compliant tape and reel option.

Features and Benefits

- Available in full range of colors: Red, Red Orange, Amber, Green, Blue, Royal Blue, Cool White, Neutral White and Warm White
- Energy efficient
- Compatible with reflow soldering process
- High current operation
- Long operation life
- Wide viewing angle
- Silicone encapsulation
- Non-ESD sensitive (threshold > 16kV)

Typical Applications

- Sign backlight
- Safety, exit and emergency sign lightings
- Specialty lighting such as task lighting and reading lights
- Retail display
- Commercial lighting
- Accent or marker lightings, strip or step lightings
- Portable lightings, bicycle head lamp, torch lights.
- Decorative lighting
- Architectural lighting
- Street lighting
- Tunnel lighting
- Contour lighting



LED Solutions

1W High Power LEDs

Part Number	Color	Forward voltage (V)	Viewing Angle (°)	Color Temperature (0K)	Test Current (mA)	Flux (lm) @ 350mA			Metal Slug
						Min.	Typ.	Max.	
ASMT-AW00-NSU00	InGaN Cool White	3.5	130	4,500 - 10,000K	350	51.7	70	87.4	Electrically Isolated
ASMT-AW00-NTU00	InGaN Cool White	3.5	130	4,500 - 10,000K	350	67.2	80	99.6	Electrically Isolated
ASMT-AN00-NSU00	InGaN Neutral White	3.5	130	3,500 - 4,500K	350	51.7	70	87.4	Electrically Isolated
ASMT-AN00-NTU00	InGaN Neutral White	3.5	130	3,500 - 4,500K	350	51.7	70	87.4	Electrically Isolated
ASMT-AY00-NST00	InGaN Warm White	3.5	130	2,700 - 3,500K	350	51.7	65	87.4	Electrically Isolated
ASMT-AL00-NMPO0	InGaN Royal Blue	3.5	130	455nm	350	225mW	350mW	435mW	Electrically Isolated
ASMT-AL00-NNP00	InGaN Royal Blue	3.5	130	455nm	350	275mW	320mW	435mW	Electrically Isolated
ASMT-AB00-NLN00	InGaN Blue	3.5	130	470nm	350	10.7	15	23.5	Electrically Isolated
ASMT-AB00-NMP00	InGaN Blue	3.5	130	470nm	350	13.9	18	30.6	Electrically Isolated
ASMT-AG00-NST00	InGaN Green	3.5	130	525nm	350	51.7	65	87.4	Electrically Isolated
ASMT-AA00-AQR00	AllInGaP Amber	2.4	130	590nm	350	30.6	43	51.7	Non-electrically Isolated
ASMT-AH00-AQR00	AllInGaP Red-Orange	2.4	130	615nm	350	30.6	43	51.7	Non-electrically Isolated
ASMT-AR00-AQR00	AllInGaP Red	2.4	130	625nm	350	30.6	43	51.7	Non-electrically Isolated

LED Solutions

1W Mini High Power LEDs

Part Number	Color	Forward voltage (V)	Viewing Angle (°)	Color Temperature (0K)	Test Current (mA)	Flux (lm)			Metal Slug
						Min.	Typ.	Max.	
ASMT-JW11-NTT01	InGaN Cool White	3.5	140	4,500K - 10,000K	350	67.2	70	87.4	Electrically Isolated
ASMT-JN11-NST01	InGaN Neutral White	3.5	140	3,500K - 4,500K	350	51.7	65	87.4	Electrically Isolated
ASMT-JY11-NST01	InGaN Warm White	3.5	140	2,700K - 3,500K	350	51.7	60	87.4	Electrically Isolated
ASMT-JL11-NMP01	InGaN Royal Blue	3.5	165	455nm	350	225mW	320mW	435mW	Electrically Isolated
ASMT-JB11-NLN01	InGaN Blue	3.5	165	470nm	350	10.7	15	23.5	Electrically Isolated
ASMT-JG11-NST01	InGaN Green	3.5	165	525nm	350	51.7	70	87.4	Electrically Isolated
ASMT-JA10-ARS01	AllnGaP Amber	2.4	165	590nm	350	39.8	45	67.2	Non-electrically Isolated
ASMT-JH10-ARS01	AllnGaP Red-Orange	2.4	165	615nm	350	39.8	45	67.2	Non-electrically Isolated
ASMT-JR10-ARS01	AllnGaP Red	2.4	165	625nm	350	39.8	45	67.2	Non-electrically Isolated

3W Mini High Power LEDs

Part Number	Color	Forward voltage (V)	Viewing Angle (°)	Color Temperature (0K)	Test Current (mA)	Flux (lm) / Radiometric Power (mW)			Metal Slug
						@ 350mA		@ 700mA	
						Min.	Typ.	Max.	
ASMT-JW31-NTV01	InGaN Cool White	3.5	140	4,500K - 10,000K	350	85	113.6	150	Electrically Isolated
ASMT-JW31-NUV01	InGaN Cool White	3.5	140	4,500K - 10,000K	350	95	113.6	160	Electrically Isolated
ASMT-JN31-NTV01	InGaN Neutral White	3.5	140	3,500K - 4,500K	350	85	113.6	150	Electrically Isolated
ASMT-JN31-NUV01	InGaN Neutral White	3.5	140	3,500K - 4,500K	350	95	113.6	160	Electrically Isolated
ASMT-JY31-NSU01	InGaN Warm White	3.5	140	2,700K - 3,500K	350	70	99.6	120	Electrically Isolated
ASMT-JL31-NPQ01	InGaN Royal Blue	3.5	165	455nm	350	435mW	515mW	650mW	Electrically Isolated
ASMT-JB31-NMP01	InGaN Blue	3.5	165	470nm	350	20	30.6	33	Electrically Isolated
ASMT-JG31-NST01	InGaN Green	3.5	165	525nm	350	70	87.4	120	Electrically Isolated
ASMT-JA30-ARS01	AllnGaP Amber	2.4	165	590nm	350	45	67.2	80	Non-electrically Isolated
ASMT-JH30-ARS01	AllnGaP Red-Orange	2.4	165	615nm	350	45	67.2	80	Non-electrically Isolated
ASMT-JR30-ARS01	AllnGaP Red	2.4	165	625nm	350	45	67.2	80	Non-electrically Isolated

LED Solutions

1W High Power LED

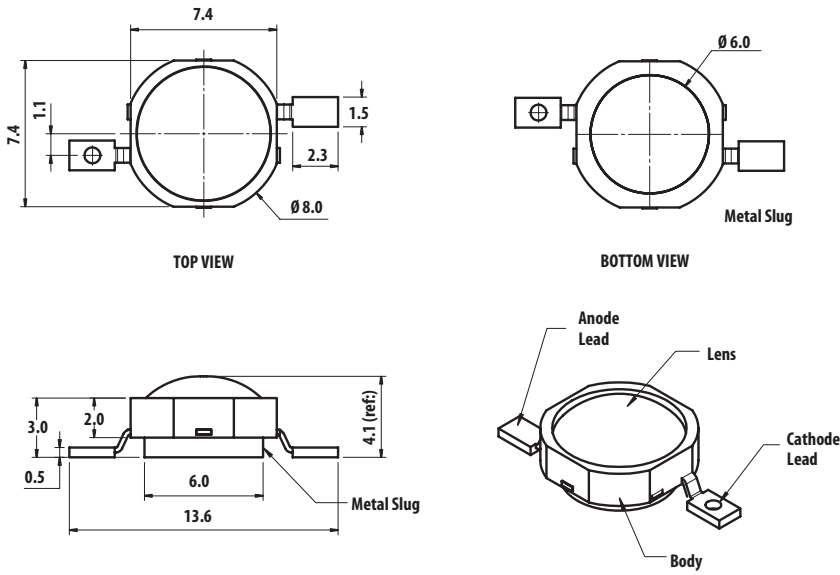

Notes:

1. All dimensions in millimeter.
2. Tolerance is ± 0.1 mm unless otherwise specified.
3. Metal slug is connected to anode for electrically non-isolated package.
4. Terminal finish: Ag plating.

1W & 3W Mini High Power LED

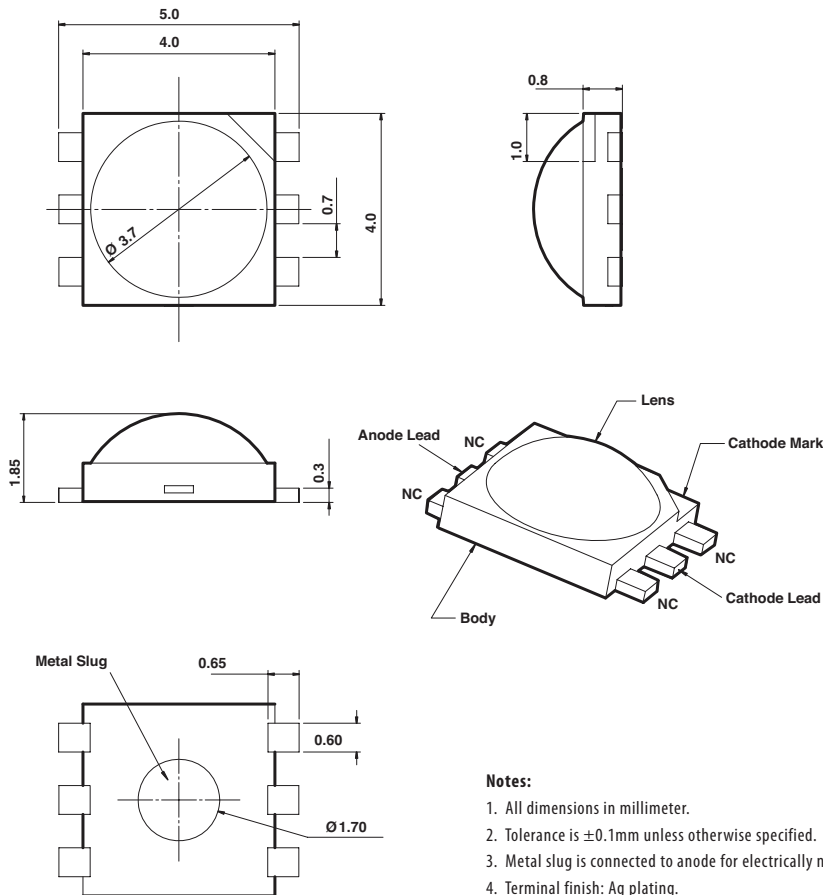

Notes:

1. All dimensions in millimeter.
2. Tolerance is ± 0.1 mm unless otherwise specified.
3. Metal slug is connected to anode for electrically non-isolated package.
4. Terminal finish: Ag plating.



Standard Through-hole Lamps

Description

Avago Technologies offers four types of technology-based LEDs. GaP and AlGaAs based technologies are suitable for low to moderate light output requirements. AllnGaP and InGaN product offering are suitable for high brightness needs. Through-hole LEDs are offered in a variety of packages such as 3 mm, 5 mm, rectangular, bicolor, integrated resistors in standard and low current options.

These devices are molded from advanced optical grade epoxy, which provide superior high temperature performance and excellent moisture resistance.

Through-hole LEDs are suitable for all applications requiring backlighting and status indication. Consumer electronics and automotive interiors use LEDs to add value to their products. Low power consumption, high reliability and a broad range of colors and packages are just a few reasons why.

Features and Benefits

- Excellent product quality and reliability
- Wide range of products
- Competitive pricing
- Wide operating temperature range
 - With minor electrical/optical changes
- Lower power consumption
 - High efficiency, low drive currents and low driving voltages required
- Thin, light weight and robust packaging
 - Excellent performance even under vibration and mechanical shock
- Different material technologies available in standard GaP LED lamps
 - Choice of colors (560 nm – 626 nm): Green, Yellow, Amber, Orange and Red
 - Red color using AlGaAs technology.
 - Five colors available with high luminous intensity in AllnGaP LED lamps
 - Amber (590 nm), Red (626 nm), deep Red (635 nm), Orange (605 nm) and Red-Orange (615 nm)
 - Two colors available with high luminous intensity in InGaN LED lamps
 - Blue (470 nm) and Green (527 nm)
 - Several packaging options
 - Different sizes with a clear or diffused lens, several lead configurations and different spatial radiation patterns available in bulk, ammo-pack, right angle housing and tape and reel

Typical Applications

- Consumer
 - ovens, washers, etc.
 - audio, hi-fi and electrical appliances
 - gaming and vending machines
 - electronic toys and games
- Industrial
 - sensors
 - instruments
 - measurement equipment
- Automotive and Other
 - automotive interior
 - exercise equipment
 - medical equipment
 - front panel industrial equipment

LED Indicators and Displays











Standard Through-hole LED Lamps

Part Number	Color	Dominant Wavelength (nm)	Viewing Angle	Lens	Intensity		Vf Typ. (V)	Test Current (mA)
					Min. (mcd)	Typ. (mcd)		
3 mm (T1) LED Lamps — Standard Current								
HLMP-1301-G0002	GaP Red	626	60°	Tinted, Diffused	8.6	11	1.9	10
HLMP-1321	GaP Red	626	45°	Tinted, Non-diffused	8.6	30	1.9	10
HLMP-1340	GaP Red	626	45°	Micro-tinted, Non-diffused	35.2	55	1.9	20
HLMP-1401-E0000	GaP Yellow	585	60°	Tinted, Diffused	5.7	-	2	10
HLMP-1440	GaP Yellow	585	45°	Micro-tinted, Non-diffused	23.5	45	2.1	20
HLMP-1503	GaP Green	569	60°	Tinted, Diffused	4.2	8.5	2.1	10
HLMP-1521	GaP Green	569	45°	Tinted, Non-diffused	6.7	22	2.1	10
HLMP-1540	GaP Green	569	45°	Untinted, Non-diffused	27.3	45	2.2	20
HLMP-K101	AlGaAs Red	637	60°	Tinted, Diffused	22	45	1.8	20
HLMP-K105	AlGaAs Red	637	45°	Untinted, Non-diffused	35.2	65	1.8	20
HLMP-K640	GaP Green	560	45°	Untinted, Non-diffused	4.2	21	2.2	20
HLMP-Y601-J0000	AllnGaP Red	627	45	Untinted, Non-diffused	240	680	2.2	20
HLMP-Y651-G0000	AllnGaP Deep Red	638	45	Untinted, Non-diffused	140	300	2.2	20
HLMP-Y701-G0000	AllnGaP Amber	592	45	Untinted, Non-diffused	140	400	2.2	20
HLMP-Y802-F0000	AllnGaP Green	572	45	Tinted, Non-diffused	110	240	2.4	20
HLMP-KA45-E0000	InGaN Blue	464	50	Untinted, Non-diffused	85	480	3.5	20
3 mm (T1) LED Lamps — Autoinsertable								
HLMP-NG05	AllnGaP Red	626	45°	Micro-tinted, Non-diffused	90.2	-	1.90	20
HLMP-NG07	AllnGaP Red	626	60°	Micro-tinted, Non-diffused	90.2	-	1.90	20
HLMP-NL06	AllnGaP Amber	590	60°	Micro-tinted, Non-diffused	96.2	-	2.02	20
HLMP-NS30-J0000	InGaN Blue	470	30°	Untinted, Non-diffused	240	550	3.6	20
HLMP-NM31-R0000	InGaN Green	529	30°	Untinted, Non-diffused	1500	2800	3.3	20
3 mm (T1) 5V, 12V Integrated Resistor LED Lamps								
HLMP-1621 ^[1]	GaP Yellow	585	60°	Tinted, Diffused	2.2	8	8	-
HLMP-1640-B00A2 ^[2]	GaP Green	569	60°	Tinted, Diffused	1.6	8	8	-
5 mm (T1 3/4) LED Lamps — Standard Current								
HLMP-3301	GaP Red	626	60°	Tinted, Diffused	5.4	7	1.9	10
HLMP-3401	GaP Yellow	585	60°	Tinted, Diffused	5.7	8	2	10
HLMP-3507	GaP Green	569	60°	Tinted, Diffused	4.2	5.2	2.1	10
HLMP-3950	GaP Green	569	24°	Micro-tinted, Non-diffused	111.7	265	2.2	20
HLMP-C008-U0000	AllnGaP Red	626	8°	Untinted, Non-diffused	2900	6000	1.9	20
HLMP-C025-P0000	AllnGaP Red	626	25°	Untinted, Non-diffused	500	1000	1.9	20
HLMP-C208-S0000	AllnGaP Amber	590	8°	Untinted, Non-diffused	2600	3000	1.9	20
HLMP-C225-O0000	AllnGaP Amber	590	25°	Untinted, Non-diffused	450	800	1.9	20
HLMP-C608-R0000	AllnGaP Red	635	8°	Untinted, Non-diffused	1000	2000	1.9	20
HLMP-C625-P0000	AllnGaP Red	635	25°	Untinted, Non-diffused	500	700	1.9	20
HLMP-DB25-B0000	GaN Blue	462	25°	Untinted, Non-diffused	40	100	4	20
HLMP-DM25-J0000	InGaN Green	527	25°	Untinted, Non-diffused	240	970	3.8	20
HLMP-DS25-F0000	InGaN Blue	470	25°	Untinted, Non-diffused	110	260	3.6	20
5 mm (T1 3/4) LED Lamps — Low Current								
HLMP-4700	GaP Red	626	50°	Tinted, Diffused	1.3	2.3	1.7	2
HLMP-4719	GaP Yellow	585	50°	Tinted, Diffused	0.9	2.1	1.8	2
HLMP-4740	GaP Green	569	50°	Tinted, Diffused	1	2.3	1.9	2
HLMP-D150	AlGaAs Red	637	65°	Tinted, Diffused	1.3	3	1.6	1

Notes: 1. Operating Voltage = 12V. 2. Operating Voltage = 5V.

LED Indicators and Displays

Standard Through-hole Lamps

Part Number	Color	Dominant Wavelength (nm)	Viewing Angle	Lens	Intensity		Vf Typ. (V)	Test Current (mA)
					Min. (mcd)	Typ. (mcd)		
2 mm x 5 mm Rectangular LED Lamps								
HLMP-S201	 GaP Red	626	110°	Tinted, Diffused	3.4	7.5	1.9	20
HLMP-S301	 GaP Yellow	585	110°	Tinted, Diffused	2.2	4	2.1	20
HLMP-S501	 GaP Green	569	110°	Tinted, Diffused	4.2	8	2.2	20
2mm x 5mm Bicolor Rectangular LED Lamps								
HLMP-0800	 GaP Green	570	100°	Untinted, Diffused	2.6	–	2.2	20
	 GaP Red	626	100°	Untinted, Diffused	2.1	–	1.9	20
HLMP-0805	 GaP Green	570	100°	Untinted, Diffused	2.6	–	2.2	20
	 GaP Yellow	585	100°	Untinted, Diffused	1.4	–	2.1	20
5 mm (T1 3/4) LED Lamps — Bicolor								
HLMP-4000	 GaP Green	570	65°	Untinted, Diffused	4.2	–	2.2	10
	 GaP Red	626	65°	Untinted, Diffused	2.1	–	1.9	10
HLMP-4015	 GaP Green	570	65°	Untinted, Non-Diffused	20	–	2.2	20
	 GaP Yellow	585	65°	Untinted, Non-Diffused	20	–	2.6	20

Intensity Bin Limits

Bin ID	Intensity (mcd)	
	Min.	Max.
Red / Orange 		
A	0.6	0.9
B	0.9	1.5
C	1.5	2.4
D	2.4	3.8
E	3.8	6.1
F	6.1	9.7
G	9.7	15.5
H	15.5	24.8
I	24.8	39.6
J	39.6	63.4
K	63.4	101.5
L	101.5	162.4
M	162.4	234.6
N	234.6	340.0
O	340	540
P	540	850
Q	850	1200
R	1200	1700
S	1700	2400
T	2400	3400
U	3400	4900
V	4900	7100
W	7100	10200
X	10200	14800
Y	14800	21400
Z	21400	30900

Tolerance: ±18%

Bin ID	Intensity (mcd)	
	Min.	Max.
Yellow / Amber 		
A	1.0	1.6
B	1.6	2.5
C	2.5	4.0
D	4.0	6.5
E	6.5	10.3
F	10.3	16.6
G	16.6	26.5
H	26.5	42.3
I	42.3	67.7
J	67.7	108.2
K	108.2	173.2
L	173.2	250.0
M	250	360
N	360	510
O	510	800
P	800	1250
Q	1250	1800
R	1800	2900
S	2900	4700
T	4700	7200
U	7200	11700
V	11700	18000
W	18000	27000

Tolerance: ±18%

Bin ID	Intensity (mcd)	
	Min.	Max.
Green / Emerald Green * 		
A	1.1	1.8
B	1.8	2.9
C	2.9	4.7
D	4.7	7.6
E	7.6	12.0
F	12.0	19.1
G	19.1	30.7
H	30.7	49.1
I	49.1	78.5
J	78.5	125.7
K	125.7	201.1
L	201.1	289.0
M	289	417
N	417	680
O	680	1100
P	1100	1800
Q	1800	2700
R	2700	4300
S	4300	6800
T	6800	10800
U	10800	16000
V	16000	25000
W	25000	40000

* Except InGaN Green





Tolerance: ±18%

Bin ID	Intensity (mcd)	
	Min.	Max.
InGaN Green / Blue 		
A	30	40
B	40	50
C	50	65
D	65	85
E	85	110
F	110	140
G	140	180
H	180	240
J	240	310
K	310	400
L	400	520
M	520	680
N	680	880
P	880	1150
Q	1150	1500
R	1500	1900
S	1900	2500
T	2500	3200
U	3200	4200
V	4200	5500
W	5500	7200
X	7200	9300
Y	9300	12000



Tolerance: ±15%

LED Indicators and Displays

Color Bin Limits

Bin ID	Intensity (mcd)	
	Min.	Max.
Orange 		
2	599.0	602.5
3	601.5	605.0
4	603.8	608.2
5	606.8	611.2
Yellow 		
1	582.0	584.5
3	584.5	587.0
2	587.0	589.5
4	589.5	592.0
5	592.0	593.0
Amber 		
3	584.5	587.0
2	587.0	589.5
4	589.5	592.0
6	592.0	594.5
7	594.5	597.0
Emerald Green 		
1	582.0	584.5
3	584.5	587.0
2	587.0	589.5
4	589.5	592.0
5	592.0	593.0

Tolerance: $\pm 0.5\text{nm}$

Bin ID	Intensity (mcd)	
	Min.	Max.
Green (except InGaN Green) 		
6	561.5	564.5
5	564.5	567.5
4	567.5	570.5
3	570.5	573.5
2	573.5	576.5
Yellow 		
1	520.0	524.0
3	524.0	528.0
2	528.0	532.0
4	532.0	536.0
5	536.0	540.0
Blue 		
1	460.0	464.0
2	464.0	468.0
3	468.0	472.0
4	472.0	476.0
5	476.0	480.0

Tolerance: $\pm 18\%$

LED Indicators and Displays

3 mm (T1) LED Lamps – Autoinsertable Package

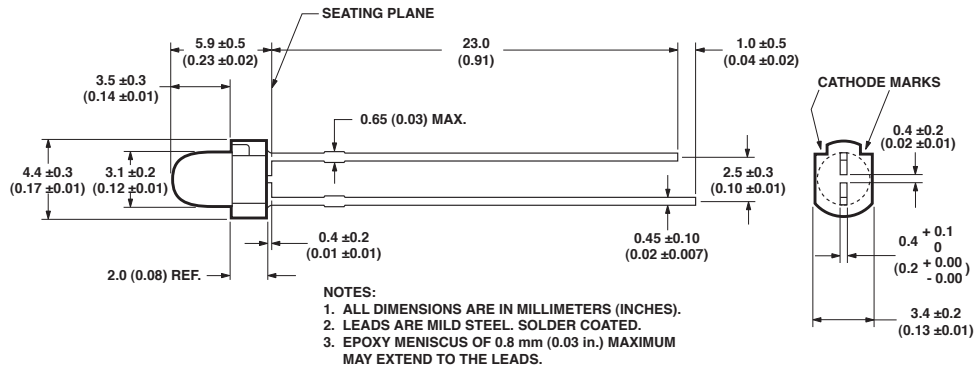

5 mm (T1-3/4) LED Lamps - Bicolor

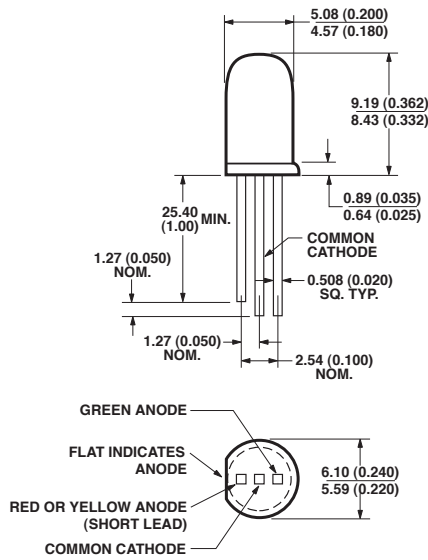

3 mm (T1) LED Lamps Package

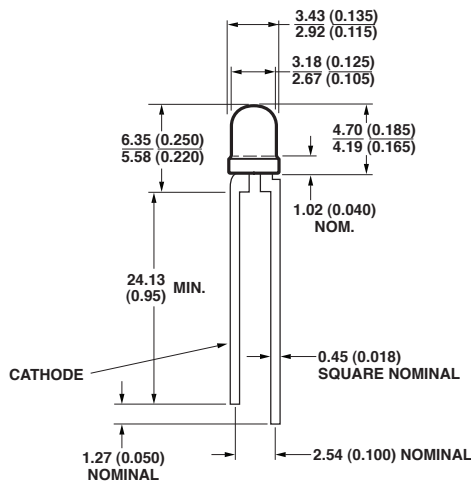

3 mm (T1) AllInGaP LED Lamps Package

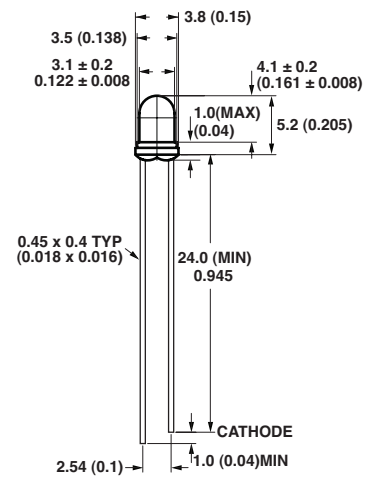

5 mm (T1 3/4) LED Lamps Package

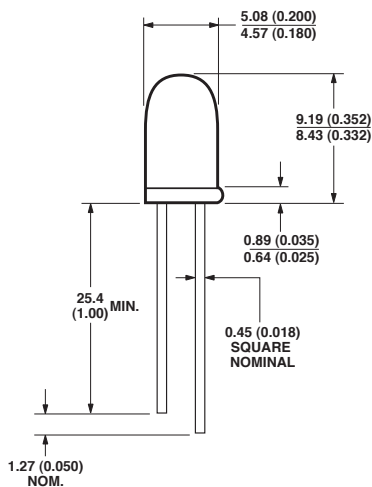

2 x 5 mm Rectangular LED Lamps Package

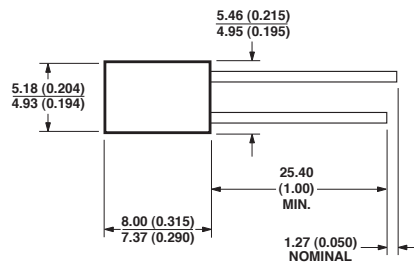

Subminiature Lamps



Description

Avago Technologies' Subminiature Lamps are designed for modern printed circuit (PC) boards, replacing through-hole mounted components for many traditional functions with smaller components, sized for closer placement.

Subminiature Lamp components are available in several lead configurations and can be used for top mount, reverse mount, and through-hole applications. The lead configurations are 'Gull Wing'–011 option, 'Yoke Bend'–021 option and 'Z Bend'–031 option. A variety of packages are available, such as flat top, dome and rectangular in standard or low current options.

Besides this, PCB based subminiature lamps are available as well. These lamps come in un-tinted, non-diffused package to cater for various product themes and ease handling applications. The small size, narrow footprint and high brightness make these LEDs excellent for backlighting, status indication and panel illumination applications.

Features and Benefits

- Excellent product quality
- Wide range of product offering
- Competitive pricing
- Can be used with surface mount or through-hole applications
- High reliability
 - No replacement for life of equipment
- Wide operating temperature range
 - Minor electrical/optical changes
- Lower power consumption
 - High efficiency, low drive currents required, low driving voltages
- Thin, light-weight and robust packaging
 - Excellent performance even under vibration and mechanical shock
- Different thin material technologies available
 - Several colors available in GaP
 - Choice of colors (560 – 626 nm): Green, Yellow, Amber, Orange, Red and Deep Red
 - Three colors available in AlnGaP
 - Amber (590 nm), Red (626 nm) and Orange (605 nm)
 - Two colors available in InGaN
 - Blue (472 nm), Green (526 nm)
- Several lead configuration options
 - Gull-wing, Yoke-bend and Z-bend
- Several Packaging options
 - Different sizes and spatial radiation patterns available in bulk, right angle housing, and tape and reel

Typical Applications

- Industrial and Communication
 - Front panel and symbol indicator
 - Keypad and push button backlighting
- Consumer
 - CD player, hi-fi audio and electrical appliances
 - Keypad and push button backlighting
- Automotive
 - Dashboard panel and symbol backlighting
 - Car radio indicators

LED Indicators and Displays

Domed Subminiature Lamps

Part Number	Color	Dominant Wavelength (nm)	Viewing Angle	Lens	Intensity		Vf Typ. (V)	Test Current (mA)
					Min. (mcd)	Typ. (mcd)		
HLMP-Q106-R00xx	TS AlGaAs Red	644	15°	Untinted, Non-diffused	100	400	1.9	20
HLMA-QG00-S00xx	AllnGaP Red	626	15°	Untinted, Non-diffused	160	500	1.9	20
HLMT-QG00	AllnGaP Red	626	15°	Untinted, Non-diffused	–	1000	2	20
HLMP-6300-F00xx	GaP Red	626	90°	Tinted, Diffused	1	10	1.8	10
HLMA-QH00-S00xx	AllnGaP Red-Orange	615	15°	Untinted, Non-diffused	160	500	1.9	20
HLMT-QH00-T00xx	AllnGaP Red-Orange	615	15°	Untinted, Non-diffused	250	500	2.4	20
HLMA-QJ00	AllnGaP Orange	605	15°	Untinted, Non-diffused	–	500	1.9	20
HLMA-QL00-S00xx	AllnGaP Amber	590	15°	Untinted, Non-diffused	160	500	1.9	20
HLMT-QL00-Txxxx	AllnGaP Amber	590	15°	Untinted, Non-diffused	250	–	2	20
HLMP-6400-F00xx	GaP Yellow	585	90°	Tinted, Diffused	1	9	2	10
HLMP-6500-F00xx	GaP Green	569	90°	Tinted, Diffused	1	7	2.1	10
HLMP-6505-L00xx	GaP Green	569	28°	Untinted, Non-diffused	10	40	2.1	10
HLMP-Q600-F00xx	GaP Emerald Green	560	90°	Tinted, Diffused	1	1.5	2.2	10
HLMP-QB00-S00xx	InGaN Blue	468	20°	Untinted, Non-diffused	–	160	290	3.7
HLMP-QM00-S00xx	InGaN Green	525	20°	Untinted, Non-diffused	–	160	690	3.7
Domed Subminiature Lamps — Low Current								
HLMP-Q150-F00xx	AlGaAs Red	637	90°	Tinted, Diffused	1	1.8	1.8	1.6
HLMP-7000-D00xx	GaP Red	626	90°	Tinted, Diffused	0.4	1	1.4	1.8
HLMP-7019-D00xx	GaP Yellow	585	90°	Tinted, Diffused	0.4	0.6	1.6	2
HLMP-7040-D00xx	GaP Green	569	90°	Tinted, Diffused	0.4	0.6	1.4	2.1

Domed Subminiature Lamps — Resistor

Part Number	Color	Dominant Wavelength (nm)	Viewing Angle	Lens	Intensity		Vf Typ. (V)	Test Current (mA)
					Min. (mcd)	Typ. (mcd)		
HLMP-6600-G00xx	GaP Red	626	90°	Tinted, Diffused	1.6	5	9.6	5
HLMP-6620-F00xx	GaP Red	626	90°	Tinted, Diffused	1	2	3.5	5
HLMP-6700-G00xx	GaP Yellow	585	90°	Tinted, Diffused	1.4	5	9.6	5
HLMP-6720-F00xx	GaP Yellow	585	90°	Tinted, Diffused	0.9	2	3.5	5
HLMP-6800-G00xx	GaP Green	569	90°	Tinted, Diffused	1.6	5	9.6	5
HLMP-6820-F00xx	GaP Green	569	90°	Tinted, Diffused	1	2	3.5	5
Flat Top Subminiature Lamps								
HLMP-P105-L00xx	AlGaAs Red	637	125°	Untinted, Non-diffused	10	30	1.8	20
HLMA-PG00-N00xx	AllnGaP Red	626	125°	Untinted, Non-diffused	25	75	1.9	20
HLMT-PG00	AllnGaP Red	626	125°	Untinted, Non-diffused	–	150	2	20
HLMP-P205-F00xx	GaP Red	626	125°	Untinted, Non-diffused	1	8	1.8	10
HLMA-PH00-N00xx	AllnGaP Red-Orange	615	125°	Untinted, Non-diffused	25	75	1.9	20
HLMT-PH00-PROxx	AllnGaP Red Orange	615	125°	Untinted, Non-diffused	40	–	2	20
HLMA-PJ00-N00xx	AllnGaP Orange	605	125°	Untinted, Non-diffused	25	75	2	20
HLMA-PL00-N00xx	AllnGaP Amber	590	125°	Untinted, Non-diffused	25	75	1.9	20
HLMT-PL00-POWxx	AllnGaP Amber	590	125°	Untinted, Non-diffused	40	150	2.4	20
HLMP-P505-G00xx	GaP Green	569	125°	Untinted, Non-diffused	1.6	6.5	2.1	10
HLMP-P605-F00xx	GaP Emerald Green	560	125°	Untinted, Non-diffused	1	1.5	2.2	10
HLMP-PB00-N00xx	InGaN Blue	468	90°	Untinted, Non-diffused	25	60	3.7	20
HLMP-PM00-N00xx	InGaN Green	528	90°	Untinted, Non-diffused	25	200	3.7	20
PCB Based Subminiature Lamps								
ASMT-BA20-AS000	AllnGaP Amber	590	15°	Untinted, Non-diffused	180	750	2.0	20
ASMT-BG20-AS000	AllnGaP Green	569	15°	Untinted, Non-diffused	180	650	2.0	20
ASMT-BR20-AS000	AllnGaP Red	626	15°	Untinted, Non-diffused	180	650	2.0	20
ASMT-BB20-NS000	InGaN Blue	468	15°	Untinted, Non-diffused	180	650	3.2	20

LED Indicators and Displays

Subminiature Lamps are also available in the following options:





Mechanical Option Number	Description
10	Right Angle
11	Tape and Reel, 1500 lamps per reel
12	Gull Wing, Bulk Packaging
21	Yoke Lead, Tape and Reel, 1500 lamps per reel
22	Yoke Lead, Bulk Packaging
31	Z-Bend, Tape and Reel, 1500 lamps per reel
32	Z-Bend, Bulk Packaging



Intensity Bin Limits

Bin ID	Intensity (mcd)	
	Min.	Max.
A	0.10	0.20
B	0.16	0.32
C	0.25	0.50
D	0.40	0.80
E	0.63	1.25
F	1.0	2.0
G	1.6	3.2
H	2.5	5.0
J	4.0	8.0
K	6.3	12.5
L	10	20
M	16	32
N	25	50
P	40	80.0
Q	63	125
R	100	200
S	160	320
T	250	500
U	400	800
V	630	1250
W	1000	2000
X	1600	3200
Y	2500	5000

Tolerance: ±18%

Color Bin Limits

Bin ID	Intensity (mcd)	
	Min.	Max.
Red Orange 		
1	617.5	625.0
2	621.0	628.5
3	624.5	632.0
Orange 		
1	596.5	600.0
2	599.0	602.5
3	601.5	604.0
4	603.8	608.2
5	606.8	611.2
6	609.8	614.2
7	612.8	617.2
8	615.8	620.2
Yellow 		
1	581.5	585.0
3	584.0	587.5
2	586.5	590.0
4	589.0	592.5
5	591.5	593.5
6	591.5	595.0
7	594.0	597.5
Green (except InGaN Green) 		
5	565	568
4	567	571
3	570	574
2	573	577
Emerald Green 		
9	552.0	556.0
8	555.0	559.0
7	558.0	562.0
6	561.0	565.0

Bin ID	Intensity (mcd)	
	Min.	Max.
InGaN Green 		
0	Full distribution	
1	520.0	530.0
2	530.0	540.0
3	520.0	525.5
4	525.0	530.0
5	530.0	535.0
6	535.0	540.0
InGaN Blue 		
0	Full distribution	
1	460.0	464.0
2	464.0	468.0
3	468.0	472.0
4	472.0	476.0
5	476.0	480.0
6	480.0	484.0

Tolerance = ±1nm



Surface Mount ChipLEDs

Description

For applications that require small size, high efficiency and low power consumption, Avago Technologies offers an extensive range of high quality ChipLEDs to meet demands for virtually any surface mount lighting requirement.

Avago Technologies' ChipLEDs are available in standard and high-brightness colors, using Avago Technologies' proven AlGaAs, AlInGaP and InGaN processes to give you the broadest range of colors from a single supplier.

Avago's ChipLEDs use the industry standard footprint, with top-mount, reverse-mount and right-angle-mount packaging options. They also have the lowest profile in the industry and are positioned to support high volume, cost-effective solutions.

ChipLED products are used in a variety of applications including LCD and push button backlighting for cellular phones, white goods and appliances, industrial measurement and control systems, and for symbol lighting and status indication in computer peripherals and consumer goods.

Low power consumption, small size and easy assembly make the ChipLED ideal for backlighting handsets as well as backlighting industrial displays.

Features and Benefits

- Small size
 - Saves PC board space
- Wide viewing angle
 - Well-suited for backlighting applications
- Intensity and color bin uniformity
 - Can be closely mounted without any intensity variations
- Available in multiple colors
 - Amber, Red, AlGaAs Red, Green, Orange, Yellow, InGaN Blue, InGaN Green, bicolor and tricolor combinations
- Variety of packages and mounting options
 - Top, reverse and right angle auto mountable
- Industry standard footprint
 - No change in existing board layout
- High volume, high reliability
 - Cost-effective solution

Typical Applications

- Telecommunications
 - Keypad and LCD backlighting for mobile phones, pagers and cordless phones
- Industrial
 - Status and symbol indicator
 - Keypad and LCD backlighting
- Consumer
 - White goods and appliances
- Computer Peripherals
 - Status indicator
- Indoor Full/Mono color sign
- Automotive interior

LED Indicators and Displays

Surface Mount ChipLEDs

Part Number	Color	Dominant Wavelength (nm)	Viewing Angle	Lens	Intensity		Vf Typ. (V)	Test Current (mA)
					Min. (mcd)	Typ. (mcd)		
Top Mount 1206 Industrial Footprint with 1.1 mm Height (C150)								
3.2 x 1.6 x 1.1 mm (L x W x H)								
HSMH-C150	AS AlGaAs Red	639	170°	Diffused	7.2	17	1.8	20
HSMD-C150	GaP Orange	604	170°	Diffused	2.8	8	2.2	20
HSMG-C150	GaP Green	572	170°	Diffused	4.5	15	2.2	20
HSMS-C150	GaP Red	626	170°	Diffused	2.8	10	2.1	20
HSMY-C150	GaP Yellow	586	170°	Diffused	2.8	8	2.1	20
HSMQ-C150	InGaN Green	527	140°	Diffused	45	145	3.4	20
HSMR-C150	InGaN Blue	473	140°	Diffused	18	55	3.4	20

Quantity: 3,000 per 7 inch reel

Top Mount 0805 Industrial Footprint with 0.8 mm Height (C170)								
2.0 x 1.25 x 0.8 mm (L x W x H)								
HSMH-C170	AS AlGaAs Red	639	170°	Diffused	7.2	17	1.8	20
HSMD-C170	GaP Orange	604	170°	Diffused	2.8	8	2.2	20
HSMG-C170	GaP Green	572	170°	Diffused	4.5	15	2.2	20
HSMS-C170	GaP Red	626	170°	Diffused	2.8	10	2.1	20
HSMY-C170	GaP Yellow	586	170°	Diffused	2.8	8	2.1	20
HSMA-C170	AS AllnGaP Amber	592	170°	Diffused	28.5	90	1.9	20
HSMC-C170	AS AllnGaP Red	626	170°	Diffused	28.5	90	1.9	20
HSML-C170	AS AllnGaP Orange	605	170°	Diffused	28.5	90	1.9	20
HSMZ-C170	TS Red	631	170°	Diffused	45	165	2.2	20
HSMN-C170	InGaN Green	525	170°	Diffused	45	120	3.3	20
HSMQ-C170	InGaN Green	527	140°	Diffused	45	145	3.4	20
HSMR-C170	InGaN Blue	473	140°	Diffused	18	55	3.4	20

Quantity: 4,000 per 7 inch reel

Top Mount 0603 Industrial Footprint with 0.8 mm Height (C190)								
1.6 x 0.8 x 0.8 mm (L x W x H)								
HSMH-C190	AS AlGaAs Red	639	170°	Diffused	7.2	17	1.8	20
HSMD-C190	GaP Orange	604	170°	Diffused	2.8	8	2.2	20
HSMG-C190	GaP Green	572	170°	Diffused	4.5	5	2.2	20
HSMS-C190	GaP Red	626	170°	Diffused	2.8	10	2.1	20
HSMY-C190	GaP Yellow	586	170°	Diffused	2.8	8	2.1	20
HSMA-C190	AS AllnGaP Amber	592	170°	Diffused	28.5	90	1.9	20
HSMC-C190	AS AllnGaP Red	626	170°	Diffused	28.5	90	1.9	20
HSML-C190	AS AllnGaP Orange	605	170°	Diffused	28.5	90	1.9	20
HSMZ-C190	TS Red	631	170°	Diffused	45	165	2.2	20
HSMN-C190	InGaN Green	525	170°	Diffused	45	120	3.3	20
HSMQ-C190	InGaN Green	527	140°	Diffused	45	145	3.4	20
HSMR-C190	InGaN Blue	473	140°	Diffused	18	55	3.4	20

Quantity: 4,000 per 7 inch reel

LED Indicators and Displays

Surface Mount ChipLEDs

Part Number	Color	Dominant Wavelength (nm)	Viewing Angle	Lens	Intensity		Vf Typ. (V)	Test Current (mA)
					Min. (mcd)	Typ. (mcd)		
Top Mount 0603 Industrial Footprint with 0.6 mm Height (C191)								
1.6 x 0.8 x 0.6 mm (L x W x H)								
HSMH-C191	AS AlGaAs Red	639	170°	Diffused	7.2	17	1.8	20
HSMD-C191	GaP Orange	604	170°	Diffused	2.8	8	2.2	20
HSMG-C191	GaP Green	572	170°	Diffused	4.5	5	2.2	20
HSMS-C191	GaP Red	626	170°	Diffused	2.8	10	2.1	20
HSMY-C191	GaP Yellow	586	170°	Diffused	2.8	8	2.1	20
HSMA-C191	AS AllnGaP Amber	592	170°	Diffused	28.5	90	1.9	20
HSMC-C191	AS AllnGaP Red	626	170°	Diffused	28.5	90	1.9	20
HSML-C191	AS AllnGaP Orange	605	170°	Diffused	28.5	90	1.9	20
HSMN-C191	InGaN Blue	470	170°	Diffused	11.2	35	3.3	20
HSMQ-C191	InGaN Green	527	140°	Diffused	45	145	3.4	20
HSMR-C191	InGaN Blue	473	140°	Diffused	18	55	3.4	20

Quantity: 4,000 per 7 inch reel

Top Mount 0805 Industrial Footprint with 0.4 mm Height (C177)								
2.0 x 1.25 x 0.4 mm (L x W x H)								
HSMD-C177	GaP Orange	604	130°	Diffused	2.8	8	2.2	20
HSMG-C177	GaP Green	572	130°	Diffused	4.5	5	2.2	20
HSMS-C177	GaP Red	626	130°	Diffused	2.8	10	2.1	20
HSMA-C177	AS AllnGaP Amber	592	130°	Diffused	28.5	90	1.9	20
HSMC-C177	AS AllnGaP Red	626	130°	Diffused	28.5	90	1.9	20
HSML-C177	AS AllnGaP Orange	605	130°	Diffused	28.5	90	1.9	20

Quantity: 4,000 per 7 inch reel

Top Mount 0603 Industrial Footprint with 0.4 mm Height (C197)								
1.6 x 0.8 x 0.4 mm (L x W x H)								
HSMD-C197	GaP Orange	604	130°	Diffused	2.8	8	2.2	20
HSMG-C197	GaP Green	572	130°	Diffused	4.5	5	2.2	20
HSMS-C197	GaP Red	626	130°	Diffused	2.8	10	2.1	20
HSMY-C197	GaP Yellow	586	130°	Diffused	2.8	8	2.1	20
HSMA-C197	AS AllnGaP Amber	592	130°	Diffused	28.5	90	1.9	20
HSMC-C197	AS AllnGaP Red	626	130°	Diffused	28.5	90	1.9	20
HSML-C197	AS AllnGaP Orange	605	130°	Diffused	28.5	90	1.9	20

Quantity: 4,000 per 7 inch reel

Top Mount 0402 Industrial Footprint with 0.4 mm Height (C280)								
1.0 x 0.5 x 0.4 mm (L x W x H)								
HSMA-C280	AS AllnGaP Amber	592	130°	Diffused	28.5	90	1.9	20
HSMC-C280	AS AllnGaP Red	626	130°	Diffused	28.5	90	1.9	20
HSMG-C280	GaP Green	572	130°	Diffused	4.5	15	2.2	20
HSMS-C280	GaP Red	626	130°	Diffused	2.8	10	2.1	20
HSMY-C280	GaP Yellow	586	130°	Diffused	2.8	8	2.1	20

Quantity: 4,000 per 7 inch reel

LED Indicators and Displays

Surface Mount ChipLEDs

Part Number	Color	Dominant Wavelength (nm)	Viewing Angle	Lens	Intensity		Vf Typ. (V)	Test Current (mA)
					Min. (mcd)	Typ. (mcd)		
Top Mount 0603 Industrial Footprint with 0.35 mm Height (C130)								
1.6 x 0.8 x 0.35 mm (L x W x H)								
HSMA-C130	AllnGaP Amber	592	110°	Diffused	28.5	87	2	20
HSMC-C130	AllnGaP Red	626	110°	Diffused	28.5	131	1.9	20
HSME-C130	AllnGaP Green	572	110°	Diffused	18	54	1.9	20
HSML-C130	AllnGaP Orange	605	110°	Diffused	28.5	139	1.9	20
HSMR-C130	InGaN Blue	473	145°	Diffused	18	55	3.4	20

Quantity: 4,000 per 7 inch reel

Leadframe Top Mount 0603 Industrial Footprint with 0.25 mm Height (CL25)								
1.6 x 0.8 x 0.25 mm (L x W x H)								
HSMR-CL25	InGaN Blue	473	120°	Non-diffused	11.2	18	2.85	5

Quantity: 4,000 per 7 inch reel

Right Angle 1 mm Height (C110)								
3.2 x 1.5 x 1.0 mm (L x W x H)								
HSMH-C110	AS AlGaAs Red	639	130°	Non-diffused	7.2	17	1.8	20
HSMC-C110	GaP Orange	604	130°	Non-diffused	2.8	8	2.2	20
HSMG-C110	GaP Green	572	130°	Non-diffused	4.5	15	2.2	20
HSMS-C110	GaP Red	626	130°	Non-diffused	2.8	10	2.1	20
HSMY-C110	GaP Yellow	586	130°	Non-diffused	2.8	8	2.1	20
HSMA-C110	AS AllnGaP Amber	592	130°	Non-diffused	28.5	95	1.9	20
HSMC-C110	AS AllnGaP Red	626	130°	Non-diffused	28.5	95	1.9	20
HSML-C110	AS AllnGaP Orange	605	130°	Non-diffused	28.5	95	1.9	20
HSMZ-C110	TS Red	631	130°	Non-diffused	45	170	2.2	20
HSMG-C110	InGaN Green	525	130°	Non-diffused	45	126	3.3	20
HSMN-C110	InGaN Blue	470	130°	Non-diffused	11.2	39	3.3	20
HSMQ-C110	InGaN Green	527	130°	Non-diffused	45	150	3.4	20
HSMR-C110	InGaN Blue	473	130°	Non-diffused	18	60	3.4	20

Quantity: 3,000 per 7 inch reel

LED Indicators and Displays

Surface Mount ChipLEDs

Part Number	Color	Dominant Wavelength (nm)	Viewing Angle	Lens	Intensity		Vf Typ. (V)	Test Current (mA)
					Min. (mcd)	Typ. (mcd)		
Right Angle 0.6 mm Height (C120)								
1.6 x 1.0 x 0.6 mm (L x W x H)								
HSMH-C120	AS AlGaAs	639	155°	Non-diffused	7.2	17	1.8	20
HSMD-C120	GaP Orange	604	155°	Non-diffused	2.8	8	2.2	20
HSMG-C120	GaP Green	572	155°	Non-diffused	4.5	15	2.2	20
HSMA-C120	AS AllnGaP Amber	592	155°	Non-diffused	28.5	90	1.9	20
HSMC-C120	AS AllnGaP Red	626	155°	Non-diffused	28.5	90	1.9	20
HSML-C120	AS AllnGaP Orange	605	155°	Non-diffused	28.5	90	1.9	20
HSMH-C120	InGaN Green	525	155°	Non-diffused	45	120	3.4	20
HSMN-C120	InGaN Blue	470	155°	Non-diffused	11.2	30	3.4	20
HSMQ-C120	InGaN Green	527	155°	Non-diffused	45	145	3.4	20
HSMR-C120	InGaN Blue	473	155°	Non-diffused	18	55	3.4	20

Quantity: 4,000 per 7 inch reel

Right Angle 0.4 mm Height (Cx00)								
1.6 x 1.0 x 0.4 mm (L x W x H)								
ASMT-CA00	AllnGaP Amber	592	150°	Non-diffused	28.5	90	1.9	20
ASMT-CB00	InGaN Blue	473	150°	Non-diffused	7.2	18	2.85	5
ASMT-CW00	InGaN White	Chromaticity Coordinates Bin A1-D2	170°	Diffused	18	35	2.85	5

Quantity: 4,000 per 7 inch reel

Reverse Mount (C265)								
3.4 x 1.25 x 1.1 mm (L x W x H)								
HSMA-C265	AS AllnGaP Amber	592	150°	Non-diffused	28.5	75	1.9	20
HSMC-C265	AS AllnGaP Red	626	150°	Non-diffused	28.5	75	1.9	20
HSME-C265	AS AllnGaP Green	572	170°	Non-diffused	18	50	2.1	20
HSML-C265	AS AllnGaP Orange	605	150°	Non-diffused	28.5	75	1.9	20
HSMG-C265	GaP Green	572	170°	Non-diffused	4.5	15	2.2	20
HSMH-C265	AS AlGaAs Red	639	170°	Non-diffused	7.2	17	1.8	20

Quantity: 3,000 per 7 inch reel

LED Indicators and Displays

Surface Mount ChipLEDs

Part Number	Color	Dominant Wavelength (nm)	Viewing Angle	Lens	Intensity		Vf Typ. (V)	Test Current (mA)
					Min. (mcd)	Typ. (mcd)		
Bicolor Top Mount 1210 Industrial Footprint (C15x)								
3.2 x 2.7 x 1.1 mm (L x W x H)								
HSMF-C153	GaP Yellow	586	170°	Diffused	2.8	8	2.1	20
	GaP Red	626	170°	Diffused	2.8	10	2.1	20
HSMF-C155	GaP Green	572	170°	Diffused	4.5	15	2.2	20
	GaP Red	626	170°	Diffused	2.8	10	2.1	20
HSMF-C156	GaP Green	572	170°	Diffused	4.5	15	2.2	20
	GaP Yellow	586	170°	Diffused	2.8	8	2.1	20
HSMF-C157	GaP Green	572	170°	Diffused	4.5	15	2.2	20
	GaP Orange	604	170°	Diffused	2.8	8	2.2	20
HSMF-C158	AllnGaP Green	572	170°	Diffused	28.5	45	2.1	20
	AllnGaP Amber	626	170°	Diffused	28.5	55	1.9	20

Quantity: 3,000 per 7 inch reel

Bicolor Top Mount 0603 Industrial Footprint (C16x)								
1.6 x 0.8 x 0.5 mm (L x W x H)								
HSMF-C162	AllnGaP Amber	592	120°	Diffused	28.5	90	1.9	20
	AllnGaP Red	626	120°	Diffused	28.5	90	1.9	20
HSMF-C163	InGaN Green	525	120°	Diffused	18	45	3.4	10
	AllnGaP Red	626	120°	Diffused	11.2	35	1.8	10
HSMF-C164	InGaN Blue	470	120°	Diffused	2.8	10	3.4	10
	AllnGaP Red	626	120°	Diffused	11.2	35	1.8	10
HSMF-C165	GaP Green	572	120°	Diffused	4.5	15	2.2	20
	GaP Red	626	120°	Diffused	2.8	10	2.1	20
HSMF-C166	GaP Green	572	120°	Diffused	4.5	15	2.2	20
	GaP Yellow	586	120°	Diffused	2.8	8	2.1	20
HSMF-C167	GaP Green	572	120°	Diffused	4.5	15	2.2	20
	GaP Orange	604	120°	Diffused	2.8	8	2.2	20
HSMF-C168	InGaN Blue	470	120°	Diffused	2.8	10	3.4	10
	InGaN Green	525	120°	Diffused	18	45	3.4	10
HSMF-C169	InGaN Blue	470	120°	Diffused	2.8	10	3.4	10
	AllnGaP Amber	592	120°	Diffused	11.2	35	1.8	10

Quantity: 4,000 per 7 inch reel

Tricolor Top Mount 1210 Industrial Footprint (C118)								
3.2 x 2.7 x 1.1 mm (L x W x H)								
HSMF-C118	GaP Green	525	130°	Diffused	45	120	3.5	20
	AllnGaP Red	626	135°	Diffused	28.5	90	1.9	20
	InGaN Blue	470	125°	Diffused	11.2	40	3.5	20

Quantity: 3,000 per 7 inch reel

Tricolor Right Angle with 1.0 mm Height (C11x)								
2.5 x 1.0 x 1.0 mm (L x W x H)								
HSMF-C113	AllnGaP Red	626	120°	Diffused	28.5	80	1.9	20
	AllnGaP Green	572	125°	Diffused	18	50	2	20
	InGaN Blue	470	125°	Diffused	28.5	60	3.4	20
HSMF-C115	AllnGaP Red	626	120°	Diffused	28.5	80	1.9	20
	InGaN Green	525	125°	Diffused	71.5	170	3.4	20
	InGaN Blue	470	125°	Diffused	28.5	60	3.4	20

Quantity: 3,000 per 7 inch reel

LED Indicators and Displays

Surface Mount ChipLEDs

Part Number	Color	Dominant Wavelength (nm)	Viewing Angle	Lens	Intensity		Vf Typ. (V)	Test Current (mA)
					Min. (mcd)	Typ. (mcd)		
Tricolor Top Mount with 0.35mm Height (C114)								
1.6 x 1.5 x 0.35 mm (L x W x H)								
HSMF-C114	AllInGaP Red	626	140°	Diffused	28.5	85	1.9	20
	InGaN Green	525	145°	Diffused	45	180	3.4	20
	InGaN Blue	470	145°	Diffused	28.5	70	3.4	20

Quantity: 4,000 per 7 inch reel

Leadframe-based (ASMT-Rx45)								
1.6 x 0.8 x 0.45 mm (L x W x H)								
ASMT-RR45	AllInGaP Red	622	145°	Diffused	50	120	2	20
ASMT-RF45	AllInGaP Yellow Green	573	145°	Diffused	30	60	2	20
ASMT-RA45	AllInGaP Amber	591	145°	Diffused	40	90	2	20

Standard Intensity Bin Limits

Bin ID	Intensity (mcd)	
	Min.	Max.
A	0.11	0.18
B	0.18	0.29
C	0.29	0.45
D	0.45	0.72
E	0.72	1.10
F	1.10	1.80
G	1.80	2.80
H	2.80	4.50
J	4.50	7.20
K	7.20	11.20
L	11.20	18.00
M	18.00	28.50
N	28.50	45.00
P	45.00	71.50
Q	71.50	112.50
R	112.50	180.00
S	180.00	285.00
T	285.00	450.00
U	450.00	715.00
V	715.00	1125.00
W	1125.00	1800.00
X	1800.00	2850.00
Y	2850.00	4500.00

Tolerance: ±15%

Color Bin Limits

Package	Color Bin	Wavelength (nm)	
		Min.	Max.
GaN/InGaN Blue	A	460.0	465.0
	B	465.0	470.0
	C	470.0	475.0
	D	475.0	480.0
InGaN Green	A	515.0	520.0
	B	520.0	525.0
	C	525.0	530.0
	D	530.0	535.0
Orange	A	597.0	600.0
	B	600.0	603.0
	C	603.0	606.0
	D	606.0	609.0
	E	609.0	612.0
	F	612.0	615.0
Red	Full Distribution		
AlGaAs Red	Full Distribution		

Tolerance: ± 1.0 nm

Package	Color Bin	Wavelength (nm)	
		Min.	Max.
Green	A	561.5	564.5
	B	564.5	567.5
	C	567.5	570.5
	D	570.5	573.5
	E	573.5	576.5
Yellow	A	582.0	584.5
	B	584.5	587.0
	C	587.0	589.5
	D	589.5	592.0
	E	592.0	594.5
	F	594.5	597.0
Amber	A	582.0	584.5
	B	584.5	587.0
	C	587.0	589.5
	D	589.5	592.0
	E	592.0	594.5
	F	594.5	597.0

Tolerance: ± 1.0 nm

LED Indicators and Displays

Surface Mount ChipLEDs

Package Dimensions

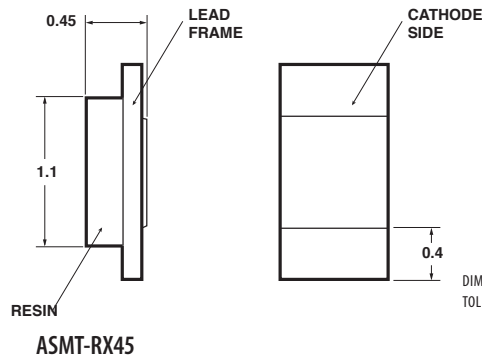
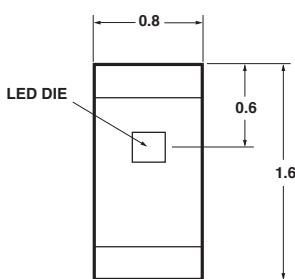
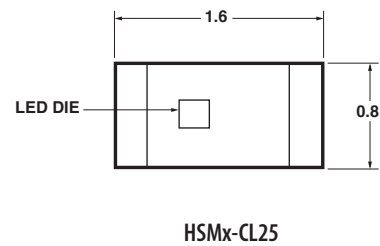
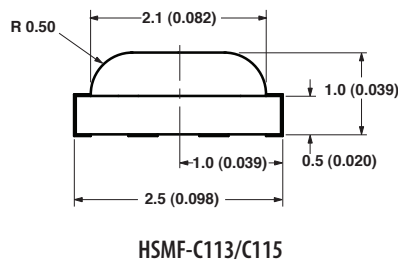
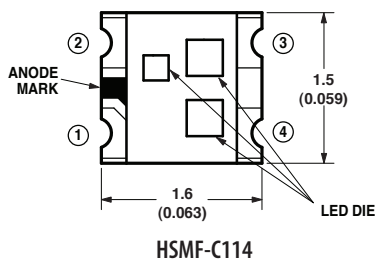
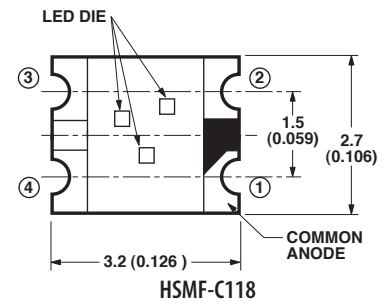
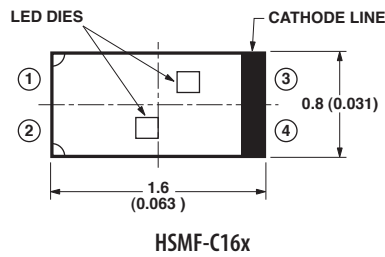
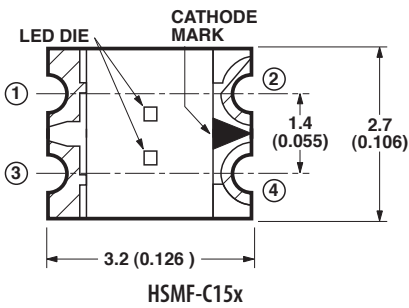
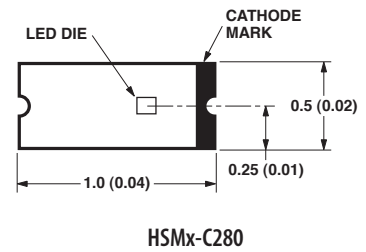
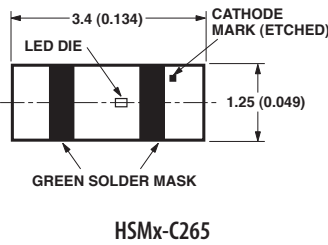
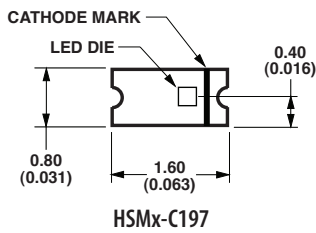
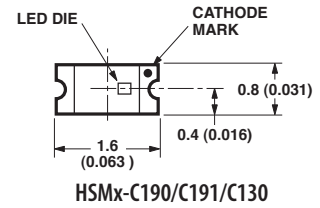
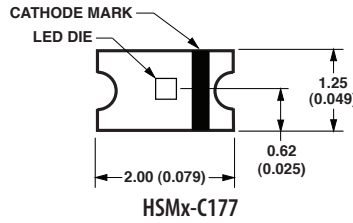
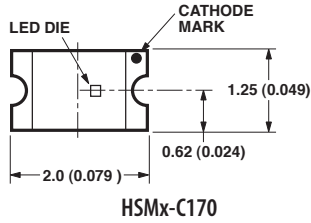
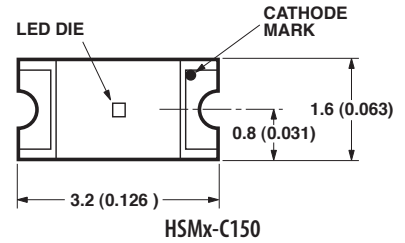
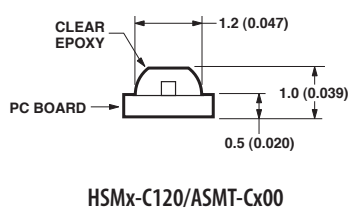
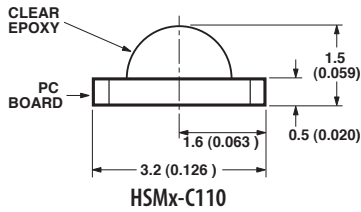

DIMENSIONS ARE IN MILLIMETERS (INCHES).
TOLERANCE IS ± 0.1 MM (± 0.004 IN.) UNLESS OTHERWISE SPECIFIED.

Auto Focus Auxiliary Flash LED



Description

Avago Technologies offer Auto Focus Auxiliary Flash LEDs in the standard package as well as miniature package. These are surface mount dome lamps that use an untinted, non-diffused lens to provide a high luminous intensity within a narrow radiation pattern.

These narrow angle SMT lamp packages are designed for applications which require long distance illumination and narrow beam pattern such as auxiliary flash for auto-focus function in digital still camera. The miniature package is also suitable for applications that have constraints in design area. These devices are compatible with Pb-free reflow soldering process.

The standard Auto Focus Auxiliary Flash LEDs are available in 530nm Green and 605nm Orange. The miniature package is available in 605nm Orange.

Eye Safety Classification

These Surface Mount AF Lamps are used for camera applications. The Orange LED is safe to be operated under all driving conditions up to 50mA; however the Green LED is limited by the current. The LEDs have lenses, which focus the beam at about 10mm from the front of the lens, from where the beam diverges relatively slowly. If the Orange LED is placed in a product, it would create a Class 1 LED to IEC/EN 60825-1 (2001) at the recommended input current as long as no collimating optics are added to the optical path. The Green LED is tested as Class 1 to IEC/EN 60825-1 (2001) under operation at 20mA. This LED is not recommended to drive beyond 20mA as part may fall in the classification of Class 2M to IEC/EN 60825-1 (2001).

Features and Benefits

- Smooth, Consistent Narrow Radiation Pattern
- Viewing angle optimized for auto focus function
- > 3m illumination distance
- Standard package: 8° viewing angle for Orange; 6° viewing angle for Green
- Miniature package: 18° View Angle
- Standard package: Small footprint with 4.8L x 4.8W x 5.33H mm
- Miniature package: 3.2L x 2.4W x 2.4H mm package dimension
- Good Intensity Output
- Compatible with 2x Solder Reflow
- Clear, Non-diffused Epoxy
- Allows easy assembly and PCB space saving.
- Compatible with reflow soldering
- IEC/EN 60825-1 Eye Safety Class 1
- RoHS compliant

Application

- Digital Still Camera

LED Indicators and Displays

Standard Auto Focus Auxiliary Flash LED

Part Number	Color	Dominant Wavelength (nm)	Viewing Angle	Lens	Intensity			Vf Typ. (V)	Test Current (mA)
					Min. (cd)	Typ. (cd)	Max. I _v (cd)		
ASMT-FJ10-ADH00	AllnGaP Orange	605	8°	Clear	9	22	—	2	20
ASMT-FG10-NFJ00	InGaN Green	530	6°	Clear	18	40	56	3.3	20

Miniature Auto Focus Auxiliary Flash LED

Part Number	Color	Dominant Wavelength (nm)	Viewing Angle	Lens	Intensity			Vf Typ. (V)	Test Current (mA)
					Min. (mcd)	Typ. (mcd)	Max. I _v (cd)		
ASMT-FJ30-AB000	AllnGaP Orange	605	18°	Clear	5.5	9	—	2	20

Iv Bin Category

Bin ID	Intensity (cd)	
	Min.	Max.
B	5.5	7.0
C	7.0	9.0
D	9.0	11.5
E	11.5	15.0
F	15.0	19.5
F+ **	18.0	19.5
G	19.5	25.5
H	25.5	33.0
I	33.0	43.0
J	43.0	56.0

Iv Tolerance = ±15%

** For ASMT-FG10-NFJ00 only

Standard Auto Focus Auxiliary Flash LED Package Dimensions

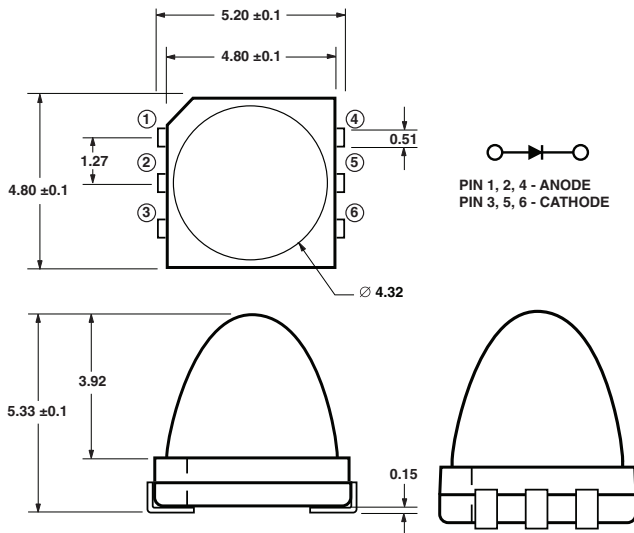

NOTES:
1. ALL DIMENSIONS IN MILLIMETERS.
2. TOLERANCE IS ±0.1 mm UNLESS OTHERWISE SPECIFIED.

Color Bin Category

Bin ID	Wavelength (nm)	
	Min.	Max.
Orange (ASMT-FJ10-xxxxx)		
A	600	604
B	604	608
C	608	612
Orange (ASMT-FJ30-xxxxx)		
1	597	600
2	600	603
3	603	606
4	606	609
5	609	612
Green		
A	515	520
B	520	525
C	525	530
D	530	535

Tolerance = ±1nm

Miniature Auto Focus Auxiliary Flash LED Package Dimensions

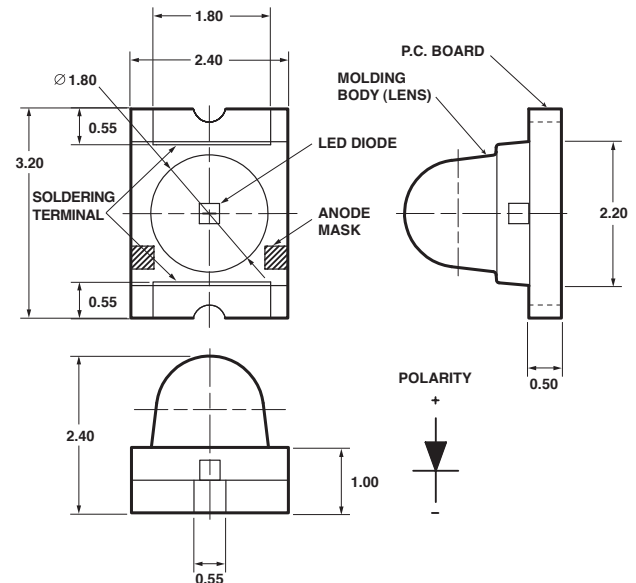

Seven-Segment Displays

Description

Avago Technologies offers a full range of seven-segment displays from low cost, standard brightness displays to high ambient light displays that produce up to 44 mcd per segment. Dual and single digit displays are available in assorted character heights and colors. They are divided into two platforms to address different market requirements in both industrial and consumer markets. Displays for industrial markets are designed for high-reliability applications and feature extremely durable packaging for high temperature environments. Consumer applications are designed for cost-sensitive, general-purpose display applications.

Product Features and Benefits

- Semiconductor (LED) light source
- Cost-effective solutions
- Flexibility for designers
- Light weight
- Lower power consumption
- Electrical power savings
- Low heat generation
- Low current devices available
- Mechanically rugged
- No wire filaments
- No moving parts
- Not sensitive to mechanical shock and vibration
- Essentially monochromatic light
- No color filter required
- Maximum use of visible light
- Easy for the eye to discern against distracting backgrounds in sunlight and adverse weather conditions
- High light output
- Industry standard size and pinout
- Categorized for luminous intensity (yellow and green categorized for color)

Industrial Applications: High Performance Seven-segment Display Package

Industrial grade products provide high peak current, automated IV/color binning and the availability of intensity and color selection. Ideal for high reliability applications such as temperature controllers, this package is extremely durable in high temperature environments with better heat dissipation through a mild steel leadframe.

Key benefits for the leadframe platform

- Heat dissipation from the package is faster than other PCB display products
- Brightness (Iv) degradation reduced over time
- Lead stability and consistency
- Solder coated leads result in better solderability
- Typical epoxy Tg is 140°C resulting in improved temperature cycling reliability

Consumer Applications: Standard Seven-segment Display Package

Designed for the cost-competitive general purpose commercial LED display applications, this package is built with a PCB substrate using ultrasonic stitch-to-stitch bonding with aluminum wire.

Key benefits for the PCB platform

- Competitive prices
- Avago Technologies quality, reliability and technical support
- Typical epoxy Tg is 100–120°C, suitable for applications that do not experience extreme temperatures and temperature cycling

Avago Technologies is committed to support the market by offering display performance and features that are specific to the designer's application requirements.

Typical Industrial Applications

High Performance Seven-segment Displays:

- Temperature controllers
- Test and measurement instrumentation
- Power converters
- Home appliance displays
- Automotive and avionic instrumentation
- Fuel pump displays
- Digital panel meters

Typical Consumer Applications





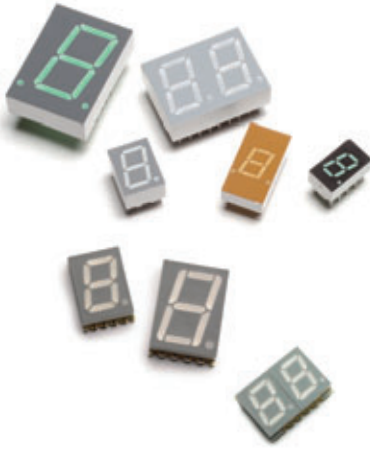



Standard Seven-segment Displays:

- Cable set-top boxes
- Electronics displays
- Gaming machines
- Point of sale terminals
- Answering machines
- Exercise equipment







LED Indicators and Displays







Through-hole Seven-Segment Displays—Leadframe Platform

Part Number	Face Color	Pin Configuration	Intensity (μcd)		Iv Test Current (mA)	Vf Typ. (V)	Vf Test Current (mA)	2 Intensity Bin Selection
			Min.	Typ.				
7.6 mm (0.3") Micro Bright Displays (right decimal point)								
GaP Red 626 nm 								
HDSP-7501	Grey	Common Anode	360	980	5	2	20	C,D
HDSP-A211	Black	Common Anode	360	980	5	2	20	
HDSP-7503	Grey	Common Cathode	360	980	5	2	20	C,D
HDSP-A213	Black	Common Cathode	360	980	5	2	20	C,D
GaP Orange 600 nm 								
HDSP-A401	Grey	Common Anode	354	720	5	2	20	
HDSP-A411	Black	Common Anode	354	720	5	2	20	
HDSP-A403	Grey	Common Cathode	354	720	5	2	20	
HDSP-A413	Black	Common Cathode	354	720	5	2	20	
GaP Yellow 586 nm 								
HDSP-7401	Grey	Common Anode	225	480	5	2.2	20	D,E
HDSP-7403	Grey	Common Cathode	225	480	5	2.2	20	D,E
High Performance Green 571 nm 								
HDSP-7801	Grey	Common Anode	860	3000	10	2.1	10	J,K
HDSP-A511	Black	Common Anode	860	3000	10	2.1	10	J,K
HDSP-7803	Grey	Common Cathode	860	3000	10	2.1	10	
HDSP-A513	Black	Common Cathode	860	3000	10	2.1	10	
GaP AlGaAs Red 637 nm 								
HDSP-A151	Grey	Common Anode	690	1400	20	1.8	20	
HDSP-A153	Grey	Common Cathode	690	1400	20	1.8	20	
7.6 mm (0.3") Micro Bright Low Current Displays (right decimal point)								
GaP AlGaAs Red 637 nm 								
HDSP-A101	Grey	Common Anode	315	600	1	1.6	1	F,G
HDSP-A103	Grey	Common Cathode	315	600	1	1.6	1	F,G
HDSP-A113	Black	Common Cathode	315	600	1	1.6	1	
GaP Red 626 nm 								
HDSP-7511	Grey	Common Anode	160	270	2	1.6	2	C,D
HDSP-7513	Grey	Common Cathode	160	270	2	1.6	2	C,D
GaP Yellow 585 nm 								
HDSP-A801	Grey	Common Anode	250	420	4	1.7	4	
HDSP-A803	Grey	Common Cathode	250	420	4	1.7	4	
GaP Green 571 nm 								
HDSP-A901	Grey	Common Anode	250	475	4	1.9	4	
HDSP-A903	Grey	Common Cathode	250	475	4	1.9	4	

LED Indicators and Displays

Through-hole Seven-Segment Displays—Leadframe Platform

Part Number	Face Color	Pin Configuration	Intensity (μcd)		Iv Test Current (mA)	Vf Typ. (V)	Vf Test Current (mA)
			Min.	Typ.			
7.6 mm (0.3") Micro Bright Overflow Displays (right decimal point)							
GaP Red 626 nm 							
HDSP-7507	Grey	Common Anode	360	980	5	2	20
HDSP-7508	Grey	Common Cathode	360	980	5	2	20
GaP Orange 600 nm 							
HDSP-A407	Grey	Common Anode	354	720	5	2	20
HDSP-A408	Grey	Common Cathode	354	720	5	2	20
GaP Yellow 586 nm 							
HDSP-7407	Grey	Common Anode	225	480	5	2.2	20
HDSP-7408	Grey	Common Cathode	225	480	5	2.2	20
GaP Green 571 nm 							
HDSP-7807	Grey	Common Anode	860	3000	10	2.1	10
HDSP-7808	Grey	Common Cathode	860	3000	10	2.1	10

Part Number	Face Color	Pin Configuration	Intensity		Iv Test Current (mA)	Vf Typ. (V)	Vf Test Current (mA)	2 Intensity Bin Selection	Decimal Point
			Min.	Typ.					
7.6 mm (0.3") Single Digit Displays									
GaP Red 626 nm 									
5082-7610	Red	Common Anode	340	800	5	2.1	20	C,D	Left
5082-7611	Red	Common Anode	340	800	5	2.1	20		Right
5082-7613	Red	Common Cathode	340	800	5	2.1	20	C,D	Right
GaP Yellow 586 nm 									
5082-7620	Yellow	Common Anode	205	620	5	2.2	20		Left
5082-7621	Yellow	Common Anode	205	620	5	2.2	20		Right
5082-7623	Yellow	Common Cathode	205	620	5	2.2	20		Right
GaP Green 571 nm 									
HDSP-3601	Green	Common Anode	860	2700	10	2.1	10		Right
HDSP-3603	Green	Common Cathode	860	2700	10	2.1	10		Right
7.6 mm (0.3") Single Digit Overflow									
GaP Red 626 nm 									
5082-7616	Red	–	340	800	5	2.1	20		Right
GaP Yellow 586 nm 									
5082-7626	Yellow	–	205	620	5	2.2	20		Right
GaP Green 571 nm 									
HDSP-3606	Green	–	860	2700	10	2.1	10		Right











LED Indicators and Displays

Through-hole Seven-Segment Displays—Leadframe Platform

Part Number	Face Color	Pin Configuration	Intensity (μcd)		Iv Test Current (mA)	Vf Typ. (V)	Vf Test Current (mA)	2 Intensity Bin Selection
			Min.	Typ.				
8 mm (0.31") Micro Bright Displays (right decimal point)								
AlGaAs Red 637 nm ■								
HDSP-U101	Grey	Common Anode	315	600	1	1.8	20	
HDSP-U111	Black	Common Anode	315	600	1	1.8	20	
HDSP-U103	Grey	Common Cathode	315	600	1	1.8	20	
HDSP-U113	Black	Common Cathode	315	600	1	1.8	20	F,G
GaP Red 626 nm ■								
HDSP-U201	Grey	Common Anode	360	980	5	2	20	
HDSP-U211	Black	Common Anode	360	980	5	2	20	C,D
HDSP-U203	Grey	Common Cathode	360	980	5	2	20	C,D
HDSP-U213	Black	Common Cathode	360	980	5	2	20	C,D
GaP Orange 600 nm ■								
HDSP-U401	Grey	Common Anode	360	980	5	2	20	
HDSP-U411	Black	Common Anode	360	980	5	2	20	
HDSP-U403	Grey	Common Cathode	360	980	5	2	20	
HDSP-U413	Black	Common Cathode	360	980	5	2	20	
GaP Yellow 586 nm ■								
HDSP-U301	Grey	Common Anode	225	480	5	2.2	20	
HDSP-U311	Black	Common Anode	225	480	5	2.2	20	
HDSP-U303	Grey	Common Cathode	225	480	5	2.2	20	
HDSP-U313	Black	Common Cathode	225	480	5	2.2	20	
GaP Green 571 nm ■								
HDSP-U501	Grey	Common Anode	860	3000	10	2.1	10	
HDSP-U511	Black	Common Anode	860	3000	10	2.1	10	K,L
HDSP-U503	Grey	Common Cathode	860	3000	10	2.1	10	K,L
HDSP-U513	Black	Common Cathode	860	3000	10	2.1	10	K,L





LED Indicators and Displays





Through-hole Seven-Segment Displays—Leadframe Platform

Part Number	Face Color	Pin Configuration	Intensity (μcd)		Iv Test Current (mA)	Vf Typ. (V)	Vf Test Current (mA)	2 Intensity Bin Selection
			Min.	Typ.				
10 mm (0.4") Single Digit Displays (right decimal point)								
AlGaAs Red 637 nm 								
HDSP-F111	Black	Common Anode	330	650	1	1.6	1	
HDSP-F101	Grey	Common Anode	330	650	1	1.6	1	E,F
HDSP-F113	Black	Common Cathode	330	650	1	1.6	1	
HDSP-F103	Grey	Common Cathode	330	650	1	1.8	1	E,F
GaP Red 626 nm 								
HDSP-F211	Black	Common Anode	420	1200	5	2	20	D,E
HDSP-F201	Grey	Common Anode	420	1200	5	2	20	D,E
HDSP-F213	Black	Common Cathode	420	1200	5	2	20	D,E
HDSP-F203	Grey	Common Cathode	420	1200	5	2	20	D,E
GaP Orange 603 nm 								
HDSP-F411	Black	Common Anode	420	1200	5	2	20	
HDSP-F401	Grey	Common Anode	420	1200	5	2	20	
HDSP-F413	Black	Common Cathode	420	1200	5	2	20	
HDSP-F403	Grey	Common Cathode	420	1200	5	2	20	
GaP Yellow 586 nm 								
HDSP-F301	Grey	Common Anode	290	800	5	2.2	20	D,E
HDSP-F303	Grey	Common Cathode	290	800	5	2.2	20	D,E
GaP Green 571 nm 								
HDSP-F511	Black	Common Anode	1030	3500	10	2.1	10	I,J
HDSP-F501	Grey	Common Anode	1030	3500	10	2.1	10	J,K
HDSP-F513	Black	Common Cathode	1030	3500	10	2.1	10	I,J
HDSP-F503	Grey	Common Cathode	1030	3500	10	2.1	10	J,K
10 mm (0.4") Overflow Displays (right decimal point)								
AlGaAs Red 637 nm 								
HDSP-F107	Grey	Common Anode	330	650	1	1.6	1	
HDSP-F108	Grey	Common Cathode	330	650	1	1.6	1	
GaP Red 626 nm 								
HDSP-F207	Grey	Common Anode	420	1200	5	2	20	
HDSP-F208	Grey	Common Cathode	420	1200	5	2	20	
GaP Orange 603 nm 								
HDSP-F407	Grey	Common Anode	420	1200	5	2	20	
HDSP-F408	Grey	Common Cathode	420	1200	5	2	20	
GaP Yellow 586 nm 								
HDSP-F307	Grey	Common Anode	290	800	5	2.2	20	
HDSP-F308	Grey	Common Cathode	290	800	5	2.2	20	
GaP Green 571 nm 								
HDSP-F507	Grey	Common Anode	1030	3500	10	2.1	10	
HDSP-F508	Grey	Common Cathode	1030	3500	10	2.1	10	

LED Indicators and Displays





Through-hole Seven-Segment Displays—Leadframe Platform

Part Number	Face Color	Pin Configuration	Intensity		Iv Test Current (mA)	Vf Typ. (V)	Vf Test Current (mA)	Decimal Point
			Min.	Typ.				
10 mm (0.4") Slim Font Single Digit Displays								
AlGaAs Red 637 nm 								
HDSP-315H	Grey	Common Anode	180	650	1	1.8	1	Right
HDSP-316H	Grey	Common Cathode	180	650	1	1.8	1	Right
GaP Red 626 nm 								
HDSP-315E	Grey	Common Anode	450	2600	10	1.9	10	Right
HDSP-316E	Grey	Common Cathode	450	2600	10	1.9	10	Right
GaP Red 626 nm — Low Current 								
HDSP-315L	Grey	Common Anode	180	370	2	2.1	2	Right
HDSP-316L	Grey	Common Cathode	180	370	2	2.1	2	Right
GaP Yellow 586 nm 								
HDSP-315Y	Grey	Common Anode	450	1800	10	2	10	Right
HDSP-316Y	Grey	Common Cathode	450	1800	10	2	10	Right
GaP Green 571 nm 								
HDSP-315G	Grey	Common Anode	450	5000	10	2.1	10	Right
HDSP-316G	Grey	Common Cathode	450	5000	10	2.1	10	Right

Part Number	Face Color	Pin Configuration	Intensity		Iv Test Current (mA)	Vf Typ. (V)	Vf Test Current (mA)	2 Intensity Bin Selection	Decimal Point
			Min.	Typ.					
10 mm (0.4") Slim Font Single Digit Displays									
AlGaAs Red 637 nm 									
HDSP-E106	Grey	—	390	650	1	1.6	1		Right
GaP Red 626 nm 									
HDSP-E106	Grey	—	390	650	1	1.6	1		Right
GaP Red 626 nm — Low Current 									
5082-7656	Red	—	340	1115	5	2.1	20		Right
GaP Yellow 586 nm 									
5082-7666	Yellow	—	290	835	5	2.2	20		Right
GaP Green 571 nm 									
HDSP-4606	Grey	—	1030	4000	10	2.1	10	I,J	Right

LED Indicators and Displays

Through-hole Seven-Segment Displays—Leadframe Platform

Part Number	Face Color	Pin Configuration	Intensity (μcd)		I _v Test Current (mA)	V _f Typ. (V)	V _f Test Current (mA)
			Min.	Typ.			
10 mm (0.4") Dual Digit Displays (right decimal point)							
AlGaAs Red 637 nm 							
HDSP-G111	Black	Common Anode	330	650	1	1.6	1
HDSP-G101	Grey	Common Anode	330	650	1	1.6	1
HDSP-G113	Black	Common Cathode	330	650	1	1.6	1
HDSP-G103	Grey	Common Cathode	330	650	1	1.6	1
GaP Red 626 nm 							
HDSP-G211	Black	Common Anode	420	1200	5	2	2
HDSP-G201	Grey	Common Anode	420	1200	5	2	20
HDSP-G213	Black	Common Cathode	420	1200	5	2	20
HDSP-G203	Grey	Common Cathode	420	1200	5	2	20
GaP Orange 603 nm 							
HDSP-G411	Black	Common Anode	420	1200	5	2	20
HDSP-G401	Grey	Common Anode	420	1200	5	2	20
HDSP-G413	Black	Common Cathode	420	1200	5	2	20
HDSP-G403	Grey	Common Cathode	420	1200	5	2	20
GaP Yellow 586 nm 							
HDSP-G301	Grey	Common Anode	290	800	5	2.2	20
HDSP-G303	Grey	Common Cathode	290	800	5	2.2	20
GaP Green 571 nm 							
HDSP-G511	Black	Common Anode	1030	3500	10	2.1	10
HDSP-G501	Grey	Common Anode	1030	3500	10	2.1	10
HDSP-G513	Black	Common Cathode	1030	3500	10	2.1	10
HDSP-G503	Grey	Common Cathode	1030	3500	10	2.1	10





LED Indicators and Displays

Through-hole Seven-Segment Displays—Leadframe Platform

Part Number	Face Color	Pin Configuration	Intensity		I _v Test Current (mA)	V _f Typ. (V)	V _f Test Current (mA)	2 Intensity Bin Selection	Decimal Point
			Min.	Typ.					
10.9 mm (0.43") Single Digit Displays									
AlGaAs Red 637 nm ■									
HDSP-E101	Grey	Common Anode	390	650	1	1.6	1	E,F	Right
HDSP-E103	Grey	Common Cathode	390	650	1	1.6	1		Right
GaP Red 626 nm ■									
5082-7650	Red	Common Anode	340	1115	5	2.1	20	D,E	Left
5082-7651	Red	Common Anode	340	1115	5	2.1	20	D,E	Right
5082-7653	Red	Common Cathode	340	1115	5	2.1	20	D,E	Right
GaP Red 626 nm — Low Current ■									
HDSP-3350	Red	Common Anode	200	300	2	1.6	2		Left
HDSP-3351	Red	Common Anode	200	300	2	1.6	2		Right
HDSP-3353	Red	Common Cathode	200	300	2	1.6	2		Right
GaP Yellow 586 nm ■									
5082-7660	Yellow	Common Anode	290	835	5	2.2	20		Left
5082-7661	Yellow	Common Anode	290	835	5	2.2	20		Right
5082-7663	Yellow	Common Cathode	290	835	5	2.2	20		Right
GaP Green 571 nm ■									
HDSP-4600	Grey	Common Anode	1030	4000	10	2.1	10		Left
HDSP-4601	Grey	Common Anode	1030	4000	10	2.1	10		Right
HDSP-4603	Grey	Common Cathode	1030	4000	10	2.1	10	I,J	Right







LED Indicators and Displays

Through-hole Seven-Segment Displays—Leadframe Platform

Part Number	Face Color	Pin Configuration	Intensity		I _v Test Current (mA)	V _f Typ. (V)	V _f Test Current (mA)	2 Intensity Bin Selection	Decimal Point
			Min.	Typ.					
13 mm (0.56") Slim Font Displays									
AlGaAs Red 637 nm 									
HDSP-515H	Grey	Common Anode	180	650	1	1.8	1	G,H	Right
HDSP-516H	Grey	Common Cathode	180	650	1	1.8	1		Right
GaP Red 626 nm 									
HDSP-515E	Grey	Common Anode	450	2600	10	1.9	10		Right
HDSP-516E	Grey	Common Cathode	450	2600	10	1.9	10		Right
GaP Red 626 nm — Low Current 									
HDSP-515L	Grey	Common Anode	180	370	2	2.1	2	F,G	Right
HDSP-516L	Grey	Common Cathode	180	370	2	2.1	2		Right
GaP Yellow 586 nm 									
HDSP-515Y	Grey	Common Anode	450	1800	10	2	10		Right
HDSP-516Y	Grey	Common Cathode	450	1800	10	2	10		Right
GaP Green 571 nm 									
HDSP-515G	Grey	Common Anode	450	5000	10	2.1	10		Right
HDSP-516G	Grey	Common Cathode	450	5000	10	2.1	10		Right







LED Indicators and Displays

Through-hole Seven-Segment Displays—Leadframe Platform

Part Number	Face Color	Pin Configuration	Intensity (μ cd)		Iv Test Current (mA)	Vf Typ. (V)	Vf Test Current (mA)	2 Intensity Bin Selection
			Min.	Typ.				
14.2 mm (0.56") Single Digit Displays (right decimal point)								
AlGaAs Red 637 nm 								
HDSP-H111	Black	Common Anode	400	700	1	1.6	1	D,E
HDSP-H101	Grey	Common Anode	400	700	1	1.6	1	D,E
HDSP-H113	Black	Common Cathode	400	700	1	1.6	1	
HDSP-H103	Grey	Common Cathode	400	700	1	1.6	1	D,E
GaP Red 626 nm 								
HDSP-H211	Black	Common Anode	900	2800	10	2	20	G,H
HDSP-5501	Grey	Common Anode	900	2800	10	2.1	20	G,H
HDSP-H213	Black	Common Cathode	900	2800	10	2	20	G,H
HDSP-5503	Grey	Common Cathode	900	2800	10	2.1	20	G,H
GaP Red 626 nm — Low Current 								
HDSP-5551	Grey	Common Anode	270	370	2	1.6	2	
HDSP-5553	Grey	Common Cathode	270	370	2	1.6	2	B,C
GaP Orange 600 nm 								
HDSP-H411	Black	Common Anode	1190	2000	10	2	20	
HDSP-H401	Grey	Common Anode	1190	2000	10	2	20	
HDSP-H413	Black	Common Cathode	1190	2000	10	2	20	
HDSP-H403	Grey	Common Cathode	1190	2000	10	2	20	
GaP Yellow 586 nm 								
HDSP-5701	Grey	Common Anode	600	1800	10	2.1	20	F,G
HDSP-5703	Grey	Common Cathode	600	1800	10	2.1	20	F,G
GaP Green 571 nm 								
HDSP-H511	Black	Common Anode	900	2500	10	2.1	10	G,H
HDSP-5601	Grey	Common Anode	900	2500	10	2.1	10	G,H
HDSP-H513	Black	Common Cathode	900	2500	10	2.1	10	G,H
HDSP-5603	Grey	Common Cathode	900	2500	10	2.1	10	G,H





LED Indicators and Displays

Through-hole Seven-Segment Displays—Leadframe Platform

Part Number	Face Color	Pin Configuration	Intensity (μcd)		Iv Test Current (mA)	Vf Typ. (V)	Vf Test Current (mA)	2 Intensity Bin Selection
			Min.	Typ.				
14.2 mm (0.56") Overflow Displays (right decimal point)								
AlGaAs Red 637 nm 								
HDSP-H107	Grey	Common Anode	400	700	1	1.6	1	
HDSP-H108	Grey	Common Cathode	400	700	1	1.6	1	
GaP Red 626 nm 								
HDSP-5507	Grey	Common Anode	900	2800	10	2.1	20	G,H
HDSP-5508	Grey	Common Cathode	900	2800	10	2.1	20	G,H
GaP Red 626 nm — Low Current 								
HDSP-5557	Grey	Common Anode	270	370	2	1.6	2	
HDSP-5558	Grey	Common Cathode	270	370	2	1.6	2	
GaP Orange 600 nm 								
HDSP-H407	Grey	Common Anode	1190	2000	10	2	20	
HDSP-H408	Grey	Common Cathode	1190	2000	10	2	20	
GaP Yellow 586 nm 								
HDSP-5707	Grey	Common Anode	600	1800	10	2.1	20	
HDSP-5708	Grey	Common Cathode	600	1800	10	2.1	20	
GaP Green 571 nm 								
HDSP-5607	Grey	Common Anode	900	2500	10	2.1	10	
HDSP-5608	Grey	Common Cathode	900	2500	10	2.1	10	





LED Indicators and Displays

Through-hole Seven-Segment Displays—Leadframe Platform

Part Number	Face Color	Pin Configuration	Intensity		I _v Test Current (mA)	V _f Typ. (V)	V _f Test Current (mA)	2 Intensity Bin Selection	Decimal Point
			Min.	Typ.					
20 mm (0.8") Single Digit Displays									
AlGaAs Red 637 nm 									
HDSP-N100	Grey	Common Anode	270	590	1	1.6	1		Left
HDSP-N101	Grey	Common Anode	270	590	1	1.6	1		Right
HDSP-N103	Grey	Common Cathode	270	590	1	1.6	1		Right
HDSP-N105	Grey	Common Cathode	270	590	1	1.6	1		Left
GaP Red 626 nm 									
HDSP-3901	Grey	Common Anode	3350	7000 Peak (1/5 df)		2.6	100	E,F	Right
HDSP-3903	Grey	Common Cathode	3350	7000		2.6	100	E,F	Right
HDSP-3905	Grey	Common Cathode	3350	7000		2.6	100		Left
GaP Orange 600 nm 									
HDSP-N401	Grey	Common Anode	2230	– Peak (1/5 df)	100 mA	2.6	100		Right
HDSP-N403	Grey	Common Cathode	2230	–		2.6	100		Right
GaP Yellow 586 nm 									
HDSP-4200	Grey	Common Left Hand	2200	7000 Peak (1/5 df)	100 mA	2.6	100		Left
HDSP-4201	Grey	Common Anode	2200	7000		2.6	100		Right
HDSP-4203	Grey	Common Cathode	2200	7000		2.6	100		Right
HDSP-4205	Grey	Common Cathode	2200	7000		2.6	100		Left
GaP Green 571 nm 									
HDSP-8600	Grey	Common Anode	680	1500	10	2.1	10		Left
HDSP-8601	Grey	Common Anode	680	1500	10	2.1	10	E,F	Right
HDSP-8603	Grey	Common Cathode	680	1500	10	2.1	10	E,F	Right
HDSP-8605	Grey	Common Cathode	680	1500	10	2.1	10		Left









LED Indicators and Displays

Through-hole Seven-Segment Displays—Leadframe Platform

Part Number	Face Color	Pin Configuration	Intensity		Iv Test Current (mA)	Vf Typ. (V)	Vf Test Current (mA)	Decimal Point
			Min.	Typ.				
20 mm (0.8") Single Digit Overflow Displays								
AlGaAs Red 637 nm 								
HDSP-N106	Grey	–	270	590	1	1.6	1	Left
GaP Red 626 nm 								
HDSP-3906	Grey	–	3350	7000 Peak (1/5 df)	100 mA	2.6	100	Right
GaP Orange 600 nm 								
HDSP-N406	Grey	–	2230	7000 Peak (1/5 df)	100 mA	2.6	100	Right
GaP Yellow 586 nm 								
HDSP-4206	Grey	–	2200	7000 Peak (1/5 df)	100 mA	2.6	100	Right
GaP Green 571 nm 								
HDSP-8606	Grey	–	680	1500	10	2.1	10	Right













LED Indicators and Displays

Through-hole Seven-Segment Displays—PCB Platform

Part Number	Face Color	Pin Configuration	Intensity (μcd)		Iv Test Current (mA)	Vf Typ. (V)	Vf Test Current (mA)	Decimal
			Min.	Typ.				
7.62 mm (0.3") Single Digit Display								
GaP Red 620 nm 								
HDSP-331E	Grey	Common Anode	800	1800	10	2.05	20	Right & Left
HDSP-333E	Grey	Common Cathode	800	1800	10	2.05	20	Right
HDSP-334E	Grey	Common Cathode	800	1800	10	2.05	20	Right
GaP Green 573 nm 								
HDSP-331G	Grey	Common Anode	800	2000	10	2.25	20	Right & Left
HDSP-333G	Grey	Common Cathode	800	2000	10	2.25	20	Right
HDSP-334G	Grey	Common Cathode	800	2000	10	2.25	20	Right
AlGaAs Red 643 nm 								
HDSP-331A	Grey	Common Anode	2001	4200	10	1.85	20	Right & Left
HDSP-333A	Grey	Common Cathode	2001	4200	10	1.85	20	Right
HDSP-334A	Grey	Common Cathode	2001	4200	10	1.85	20	Right
GaP Yellow 590 nm 								
HDSP-331Y	Grey	Common Anode	800	1500	10	2.15	20	Right & Left
HDSP-333Y	Grey	Common Cathode	800	1500	10	2.15	20	Right
HDSP-334Y	Grey	Common Cathode	800	1500	10	2.15	20	Right
10 mm (0.4") Slim Font Single Digit Display								
GaP Red 625 nm 								
HDSP-301E	Grey	Common Anode	1251	2000	10	1.90	20	Right
HDSP-303E	Grey	Common Cathode	1251	2000	10	1.90	20	Right
GaP Green 573 nm 								
HDSP-301G	Grey	Common Anode	2001	3200	10	2.25	20	Right
HDSP-303G	Grey	Common Cathode	2001	3200	10	2.25	20	Right
AlGaAs Red 643 nm 								
HDSP-301A	Grey	Common Anode	320	505	1	1.80	20	Right
HDSP-303A	Grey	Common Cathode	320	505	1	1.80	20	Right
GaP Yellow 590 nm 								
HDSP-301Y	Grey	Common Anode	1251	2000	10	2.15	20	Right
HDSP-303Y	Grey	Common Cathode	1251	2000	10	2.15	20	Right











LED Indicators and Displays

Through-hole Seven-Segment Displays—PCB Platform

Part Number	Face Color	Pin Configuration	Intensity (μcd)		I _v Test Current (mA)	V _f Typ. (V)	V _f Test Current (mA)	Decimal
			Min.	Typ.				
10.16 mm (0.4") Single Digit Display								
GaP Red 620 nm 								
HDSP-311E	Grey	Common Anode	1250	3200	10	2.05	20	Right
HDSP-313E	Grey	Common Cathode	1250	3200	10	2.05	20	Right
GaP Green 573 nm 								
HDSP-311G	Grey	Common Anode	1250	3200	10	2.25	20	Right
HDSP-313G	Grey	Common Cathode	1250	3200	10	2.25	20	Right
AlGaAs Red 643 nm 								
HDSP-311A	Grey	Common Anode	3200	7500	10	1.85	20	Right
HDSP-313A	Grey	Common Cathode	3200	7500	10	1.85	20	Right
GaP Yellow 590 nm 								
HDSP-311Y	Grey	Common Anode	800	1500	10	2.15	20	Right
HDSP-313Y	Grey	Common Cathode	800	1500	10	2.15	20	Right
10.16 mm (0.4") Dual Digit Display								
GaP Red 620 nm 								
HDSP-G01E	Grey	Common Anode	1250	2600	10	2.05	20	–
HDSP-G03E	Grey	Common Cathode	1250	2600	10	2.05	20	–
GaP Green 573 nm 								
HDSP-G01G	Grey	Common Anode	1250	3200	10	2.25	20	–
HDSP-G03G	Grey	Common Cathode	1250	3200	10	2.25	20	–
AlGaAs Red 643nm 								
HDSP-G01A	Grey	Common Anode	3200	6500	10	1.85	20	–
HDSP-G03A	Grey	Common Cathode	3200	6500	10	1.85	20	–
GaP Yellow 590 nm 								
HDSP-G01Y	Grey	Common Anode	800	1500	10	2.15	20	–
HDSP-G03Y	Grey	Common Cathode	800	1500	10	2.15	20	–
13 mm (0.56") Slim Font Single Digit Display								
GaP Red 625 nm 								
HDSP-561E	Grey	Common Anode	2001	3526	10	1.90	20	Right
HDSP-563E	Grey	Common Cathode	2001	3526	10	1.90	20	Right
GaP Green 573 nm 								
HDSP-561G	Grey	Common Anode	3201	5601	10	2.25	20	Right
HDSP-563G	Grey	Common Cathode	3201	5601	10	2.25	20	Right
AlGaAs Red 643 nm 								
HDSP-561A	Grey	Common Anode	1010	2800	10	2.1	20	Right
HDSP-563A	Grey	Common Cathode	1010	2800	10	2.1	20	Right
GaP Yellow 590 nm 								
HDSP-561Y	Grey	Common Anode	506	878	1	1.80	20	Right
HDSP-563Y	Grey	Common Cathode	506	878	1	1.80	20	Right











LED Indicators and Displays

Through-hole Seven-Segment Displays—PCB Platform

Part Number	Face Color	Pin Configuration	Intensity (μcd)		Iv Test Current (mA)	Vf Typ. (V)	Vf Test Current (mA)	Decimal
			Min.	Typ.				
14.2 mm (0.56") Single Digit Displays								
Blue 466 nm 								
HDSP-501B	Grey	Common Anode	2020	3400	10	3.8	20	Right
HDSP-503B	Grey	Common Cathode	2020	3400	10	3.8	20	Right
14.22 mm (0.56") Single Digit Display								
GaP Red 620 nm 								
HDSP-511E	Grey	Common Anode	2001	4100	10	2.05	20	Right
HDSP-513E	Grey	Common Cathode	2001	4100	10	2.05	20	Right
GaP Green 573 nm 								
HDSP-511G	Grey	Common Anode	2001	4100	10	2.25	20	Right
HDSP-513G	Grey	Common Cathode	2001	4100	10	2.25	20	Right
AlGaAs Red 643 nm 								
HDSP-511A	Grey	Common Anode	3201	6500	10	1.85	20	Right
HDSP-513A	Grey	Common Cathode	3201	6500	10	1.85	20	Right
GaP Yellow 590 nm 								
HDSP-511Y	Grey	Common Anode	1251	2600	10	2.15	20	Right
HDSP-513Y	Grey	Common Cathode	1251	2600	10	2.15	20	Right
14.2 mm (0.56") Dual Digit Displays								
GaP Yellow 587 nm 								
HDSP-521Y	Grey	Common Anode	680	1800	10	2.1	20	Right
HDSP-523Y	Grey	Common Cathode	680	1800	10	2.1	20	Right
GaP Red 626 nm 								
HDSP-521E	Grey	Common Anode	1010	2800	10	2.1	20	Right
HDSP-523E	Grey	Common Cathode	1010	2800	10	2.1	20	Right
GaP Green 571 nm 								
HDSP-521G	Grey	Common Anode	1010	2500	10	2.1	10	Right
HDSP-523G	Grey	Common Cathode	1010	2500	10	2.1	10	Right
AlGaAs Red 643 nm 								
HDSP-521A	Grey	Common Anode	3201	6500	10	1.85	20	Right
HDSP-523A	Grey	Common Cathode	3201	6500	10	1.85	20	Right
20 mm (0.8") Single Digit Display								
GaP Red 626 nm 								
HDSP-815E	Grey	Common Anode	2300	4800	20	2.1	20	Right
HDSP-816E	Grey	Common Cathode	2300	4800	20	2.1	20	Right
GaP Green 571 nm 								
HDSP-815G	Grey	Common Anode	1500	3300	20	2.1	20	Right
HDSP-816G	Grey	Common Cathode	1500	3300	20	2.1	20	Right

LED Indicators and Displays

Surface Mount Seven-Segment Displays—PCB Platform

Part Number	Face Color	Pin Configuration	Intensity (mcd)		Iv Test Current (mA)	Vf Typ. (V)	Vf Test Current (mA)	Decimal
			Min.	Typ.				
7.0mm (0.28") Single Digit SMT Display								
AllInGaP Red 624 nm 								
HDSM-281C	Grey	Common Anode	3.4	7.5	10	2	20	Upper and Lower
HDSM-283C	Grey	Common Cathode	3.4	7.5	10	2	20	Upper and Lower
AllInGaP Green 571 nm 								
HDSM-281H	Grey	Common Anode	3.4	6	10	2.1	20	Upper and Lower
HDSM-283H	Grey	Common Cathode	3.4	6	10	2.1	20	Upper and Lower
AllInGaP Yellow 589 nm 								
HDSM-281F	Grey	Common Anode	3.4	8	10	2.1	20	Upper and Lower
HDSM-283F	Grey	Common Cathode	3.4	8	10	2.1	20	Upper and Lower
AllInGaP Orange 605 nm 								
HDSM-281L	Grey	Common Anode	3.4	8.5	10	2.1	20	Upper and Lower
HDSM-283L	Grey	Common Cathode	3.4	8.5	10	2.1	20	Upper and Lower
InGaN Blue 470nm 								
HDSM-281B	Grey	Common Anode	3.4	6	10	3.3	20	Upper and Lower
HDSM-283B	Grey	Common Cathode	3.4	6	10	3.3	20	Upper and Lower
7.0 mm (0.28") Dual Digit SMT Display								
AllInGaP Red 624 nm 								
HDSM-291C	Grey	Common Anode	3.4	7.5	10	2	20	Upper and Lower
HDSM-293C	Grey	Common Cathode	3.4	7.5	10	2	20	Upper and Lower
AllInGaP Green 571 nm 								
HDSM-291H	Grey	Common Anode	3.4	6	10	2.1	20	Upper and Lower
HDSM-293H	Grey	Common Cathode	3.4	6	10	2.1	20	Upper and Lower
AllInGaP Yellow 589 nm 								
HDSM-291F	Grey	Common Anode	3.4	8	10	2.1	20	Upper and Lower
HDSM-293F	Grey	Common Cathode	3.4	8	10	2.1	20	Upper and Lower
AllInGaP Orange 605 nm 								
HDSM-291L	Grey	Common Anode	3.4	8.5	10	2.1	20	Upper and Lower
HDSM-293L	Grey	Common Cathode	3.4	8.5	10	2.1	20	Upper and Lower
InGaN Blue 470nm 								
HDSM-291B	Grey	Common Anode	3.4	6	10	3.3	20	Upper and Lower
HDSM-293B	Grey	Common Cathode	3.4	6	10	3.3	20	Upper and Lower







LED Indicators and Displays

Surface Mount Seven-Segment Displays—PCB Platform cont.

Part Number	Face Color	Pin Configuration	Intensity (mcd)		Iv Test Current (mA)	Vf Typ. (V)	Vf Test Current (mA)	Decimal
			Min.	Typ.				
10 mm (0.39") Single Digit SMT Display								
AllnGaP Red 624 nm								
HDSM-431C	Grey	Common Anode	8.6	14.3	10	2	20	Right
HDSM-433C	Grey	Common Cathode	8.6	14.3	10	2	20	Right
AllnGaP Green 571 nm								
HDSM-431H	Grey	Common Anode	5.4	9	10	2.1	20	Right
HDSM-433H	Grey	Common Cathode	5.4	9	10	2.1	20	Right
AllnGaP Yellow 589 nm								
HDSM-431F	Grey	Common Anode	8.6	15	10	2.1	20	Right
HDSM-433F	Grey	Common Cathode	8.6	15	10	2.1	20	Right
AllnGaP Orange 605 nm								
HDSM-431L	Grey	Common Anode	8.6	16	10	2.1	20	Right
HDSM-433L	Grey	Common Cathode	8.6	16	10	2.1	20	Right
InGaN Blue 470nm								
HDSM-431B	Grey	Common Anode	5.4	11.2	10	3.3	20	Lower
HDSM-433B	Grey	Common Cathode	5.4	11.2	10	3.3	20	Lower
InGaN White								
HDSM-431W	Grey	Common Anode	24	40	5	2.95	5	Lower
HDSM-433W	Grey	Common Cathode	24	40	5	2.95	5	Lower
10 mm (0.39") Dual Digit SMT Display								
AllnGaP Red 624 nm								
HDSM-441C	Grey	Common Anode	8.6	14.3	10	2	20	Right
HDSM-443C	Grey	Common Cathode	8.6	14.3	10	2	20	Right
AllnGaP Green 571 nm								
HDSM-441H	Grey	Common Anode	5.4	9	10	2.1	20	Right
HDSM-443H	Grey	Common Cathode	5.4	9	10	2.1	20	Right
AllnGaP Yellow 589 nm								
HDSM-441F	Grey	Common Anode	8.6	15	10	2.1	20	Right
HDSM-443F	Grey	Common Cathode	8.6	15	10	2.1	20	Right
AllnGaP Orange 605 nm								
HDSM-441L	Grey	Common Anode	8.6	16	10	2.1	20	Right
HDSM-443L	Grey	Common Cathode	8.6	16	10	2.1	20	Right
InGaN Blue 470nm								
HDSM-441B	Grey	Common Anode	5.4	11.2	10	3.3	20	Lower
HDSM-443B	Grey	Common Cathode	5.4	11.2	10	3.3	20	Lower
InGaN White								
HDSM-441W	Grey	Common Anode	24	40	5	2.95	5	Lower
HDSM-443W	Grey	Common Cathode	24	40	5	2.95	5	Lower
14.22 mm (0.56") Single Digit SMT Display								
AllnGaP Red 624 nm								
HDSM-531C	Grey	Common Anode	9	16	10	2	20	Right
HDSM-533C	Grey	Common Cathode	9	16	10	2	20	Right
AllnGaP Green 571 nm								
HDSM-531H	Grey	Common Anode	6	10.5	10	2.1	20	Right
HDSM-533H	Grey	Common Cathode	6	10.5	10	2.1	20	Right
AllnGaP Yellow 589 nm								
HDSM-531F	Grey	Common Anode	9	20	10	2.1	20	Right
HDSM-533F	Grey	Common Cathode	9	20	10	2.1	20	Right
AllnGaP Orange 605 nm								
HDSM-531L	Grey	Common Anode	9	19.5	10	2.1	20	Right
HDSM-533L	Grey	Common Cathode	9	19.5	10	2.1	20	Right
InGaN Blue 470nm								
HDSM-531B	Grey	Common Anode	6.3	13.5	10	3.3	20	Lower
HDSM-533B	Grey	Common Cathode	6.3	13.5	10	3.3	20	Lower
InGaN White								
HDSM-531W	Grey	Common Anode	28	44	5	2.95	5	Lower
HDSM-533W	Grey	Common Cathode	28	44	5	2.95	5	Lower





LED Indicators and Displays

Surface Mount Seven-Segment Displays





Part Number	Face Color	Pin Configuration	Intensity (mcd)		Iv Test Current (mA)	Vf Typ. (V)	Vf Test Current (mA)	Decimal
			Min.	Typ.				
14.22mm (0.56") Dual Digit SMT Display								
AllInGaP Red 624 nm 								
HDSM-541C	Grey	Common Anode	9	16	10	2	20	Right
HDSM-543C	Grey	Common Cathode	9	16	10	2	20	Right
AllInGaP Green 571 nm 								
HDSM-541H	Grey	Common Anode	6	10.5	10	2.1	20	Right
HDSM-543H	Grey	Common Cathode	6	10.5	10	2.1	20	Right
AllInGaP Yellow 589 nm 								
HDSM-541F	Grey	Common Anode	9	20	10	2.1	20	Right
HDSM-543F	Grey	Common Cathode	9	20	10	2.1	20	Right
AllInGaP Orange 605 nm 								
HDSM-541L	Grey	Common Anode	9	19.5	10	2.1	20	Right
HDSM-543L	Grey	Common Cathode	9	19.5	10	2.1	20	Right
InGaN Blue 470nm 								
HDSM-541B	Grey	Common Anode	6.3	13.5	10	3.3	20	Lower
HDSM-543B	Grey	Common Cathode	6.3	13.5	10	3.3	20	Lower
InGaN White 								
HDSM-541W	Grey	Common Anode	28	44	5	2.95	5	Lower
HDSM-543W	Grey	Common Cathode	28	44	5	2.95	5	Lower

Through-hole Seven-Segment Displays—PCB Platform Luminous Intensity Categories (Typ.)





7.62 mm (0.3") Single Digit

Bin ID	Customer Iv in mcd	
	Min.	Max.
GaP Red 		
HDSP-33xE		
G	0.801	1.250
H	1.251	2.000
I	2.001	3.200
GaP Green 		
HDSP-33xG		
G	0.801	1.250
H	1.251	2.000
I	2.001	3.200
AlGaAs Red 		
HDSP-33xA		
I	2.001	3.200
J	3.201	5.050
K	5.051	8.000
GaP Yellow 		
HDSP-33xY		
G	0.801	1.250
H	1.251	2.000
I	2.001	3.200

10 mm (0.4") Slim Font Single Digit

Bin ID	Customer Iv in mcd	
	Min.	Max.
GaP Red 		
HDSP-30xE		
I	1.100	2.200
K	1.800	3.600
GaP Green 		
HDSP-30xG		
K	1.800	3.600
L	2.800	5.600
AlGaAs Red 		
HDSP-30xA		
F	0.280	0.560
G	0.450	0.900
GaP Yellow 		
HDSP-30xY		
I	1.100	2.200
K	1.800	3.600





10.16 mm (0.4") Single Digit

Bin ID	Customer Iv in mcd	
	Min.	Max.
GaP Red 		
HDSP-31xE		
H	1.251	2.000
I	2.001	3.200
J	3.201	5.050
GaP Green 		
HDSP-31xG		
H	1.251	2.000
I	2.001	3.200
J	3.201	5.050
AlGaAs Red 		
HDSP-31xA		
J	3.201	5.050
K	5.051	8.000
L	8.001	12.650
GaP Yellow 		
HDSP-31xY		
G	0.801	1.250
H	1.251	2.000
I	2.001	3.200





LED Indicators and Displays

Through-hole Seven-Segment Displays—PCB Platform Luminous Intensity Categories (Typ.)



10.16 mm (0.4"D) Dual Digit

Bin ID	Customer lv in mcd	
	Min.	Max.
GaP Red 		
HDSP-G0xE		
H	1.251	2.000
I	2.001	3.200
J	3.201	5.050
GaP Green 		
HDSP-G0xG		
H	1.251	2.000
I	2.001	3.200
J	3.201	5.050
AlGaAs Red 		
HDSP-G0xA		
J	3.201	5.050
K	5.051	8.000
L	8.001	12.650
GaP Yellow 		
HDSP-G0xY		
G	0.801	1.250
H	1.251	2.000
I	2.001	3.200



13 mm (0.56") Slim Font Single Digit

Bin ID	Customer lv in mcd	
	Min.	Max.
GaP Red 		
HDSP-56xE		
I	1.100	2.200
K	1.800	3.600
GaP Green 		
HDSP-56xG		
K	1.800	3.600
L	2.800	5.600
AlGaAs Red 		
HDSP-56xA		
F	0.280	0.560
G	0.450	0.900
GaP Yellow 		
HDSP-56xY		
I	1.100	2.200
K	1.800	3.600





10mm (0.28") Single Digit SMT Display

Bin ID	Customer lv in mcd	
	Min.	Max.
AllnGaP Green 		
HDSM-281H HDSM-283H		
L	3.401	5.400
M	5.401	8.600
AllnGaP Red/Orange/Yellow 		
HDSM-281C/281L/281F HDSM-283C/283L/283F		
L	3.401	5.400
M	5.401	8.600
N	8.601	13.700
InGaN Blue 		
HDSM-281B HDSM-283B		
L	3.401	5.400
M	5.401	8.600
N	8.601	13.700

10mm (0.28") Dual Digit SMT Display

Bin ID	Customer lv in mcd	
	Min.	Max.
AllnGaP Green 		
HDSM-291H HDSM-293H		
L	3.401	5.400
M	5.401	8.600
GAllnGaP Red/Orange/Yellow 		
HDSM-291C/291L/291F HDSM-293C/293L/293F		
L	3.401	5.400
M	5.401	8.600
N	8.601	13.700
InGaN Blue 		
HDSM-291B HDSM-293B		
L	3.401	5.400
M	5.401	8.600
N	8.601	13.700

10mm (0.39") Single Digit SMT Display

Bin ID	Customer lv in mcd	
	Min.	Max.
AllnGaP Green 		
HDSM-431H HDSM-433H		
M	5.401	8.600
N	8.601	13.700
P	13.701	21.800
AllnGaP Red/Yellow 		
HDSM-431C/431F HDSM-433C/433F		
N	8.601	13.700
P	13.701	21.800
Q	21.801	34.700
AllnGaP Orange 		
HDSM-431L HDSM-433L		
N	8.601	13.700
P	13.701	21.800
Q	21.801	34.700
R	34.701	55.200
InGaN Blue 		
HDSM-431B HDSM-433B		
M	5.401	8.600
N	8.601	13.700
P	13.701	21.800





LED Indicators and Displays

Surface Mount Seven-Segment Displays Luminous Intensity Categories (Typ.)





0.56" Single Digit

Bin ID	Customer lv in mcd	
	Min.	Max.
Blue  HDSP-50xB		
H	2.02	2.63
I	2.63	3.42
J	3.42	4.20
K	4.20	5.04



14.22 mm (0.56") Single Digit

Bin ID	Customer lv in mcd	
	Min.	Max.
GaP Red  HDSP-51xE		
I	2.001	3.200
J	3.201	5.050
K	5.051	8.000
GaP Green  HDSP-51xG		
I	2.001	3.200
J	3.201	5.050
K	5.051	8.000
AlGaAs Red  HDSP-51xA		
J	3.201	5.050
K	5.051	8.000
L	8.001	12.650
GaP Yellow  HDSP-51xY		
H	1.251	2.000
I	2.001	3.200
J	3.201	5.050





0.56" Dual Digit

Bin ID	Customer lv in mcd	
	Min.	Max.
GaP Red  HDSP-52xE		
G	2.28	3.42
H	3.42	5.13
I	5.13	7.69
GaP Yellow  HDSP-52xY		
F	1.52	2.28
G	2.28	3.42
H	3.42	5.13
GaP Green  HDSP-52xG		
G	2.28	3.42
H	3.42	5.13
AlGaAs Red  HDSP-52xA		
J	3.201	5.050
K	5.051	8.000
L	8.001	12.650

0.8" Single Digit





Bin ID	Customer lv in mcd	
	Min.	Max.
GaP Red  HDSP-81xE		
N	4.78	8.34
P	6.82	11.86
Q	9.7	16.61
GaP Green  HDSP-81xG		
P	6.82	11.86
Q	9.7	16.61
R	13.6	23.74

10mm (0.39") Dual Digit SMT Display





Bin ID	Customer lv in mcd	
	Min.	Max.
AllnGaP Green  HDSM-441H HDSM-443H		
M	5.401	8.600
N	8.601	13.700
P	13.701	21.800
AllnGaP Red/Yellow  HHDSM-441C/441F HDSM-443C/443F		
N	8.601	13.700
P	13.701	21.800
Q	21.801	34.700
AllnGaP Orange  HDSM-441L HDSM-443L		
N	8.601	13.700
P	13.701	21.800
Q	21.801	34.700
R	34.701	55.200
InGaN Blue  HDSM-441B HDSM-443B		
M	5.401	8.600
N	8.601	13.700
P	13.701	21.800

LED Indicators and Displays

14.22mm (0.56") Single SMT Display

Bin ID	Customer lv in mcd	
	Min.	Max.
AllnGaP Green  HDSM-531H HDSM-533H		
M	5.401	8.600
N	8.601	13.700
AllnGaP Red  HDSM-531C HDSM-533C		
N	8.601	13.700
P	13.701	21.800
AllnGaP Orange/Yellow  HDSM-531L/531F HDSM-533L/533F		
N	8.601	13.700
P	13.701	21.800
Q	21.801	34.700
InGaN Blue  HDSM-531B HDSM-533B		
M	5.401	8.600
N	8.601	13.700
P	13.701	21.800
Q	21.801	34.700

14.22mm (0.56") Dual Digit Display

Bin ID	Customer lv in mcd	
	Min.	Max.
AllnGaP Green  HDSM-541H HDSM-543H		
M	5.401	8.600
N	8.601	13.700
AllnGaP Red  HDSM-541C HDSM-543C		
N	8.601	13.700
P	13.701	21.800
AllnGaP Orange/Yellow  HHDSM-541L/541F HDSM-543L/543F		
N	8.601	13.700
P	13.701	21.800
Q	21.801	34.700
InGaN Blue  HDSM-541B HDSM-543B		
M	5.401	8.600
N	8.601	13.700
P	13.701	21.800
Q	21.801	34.700

LED Indicators and Displays

Through-hole Seven-Segment Displays—Leadframe Platform

7.6 mm (0.3") Micro Bright Displays Package Dimension

Part Number		
HDSP-	A151	A211
	7501	A213
	A401	A511
	A411	A513
	7401	
	7801	
	A153	
	7503	
	A403	
	A413	
	7403	
	7803	

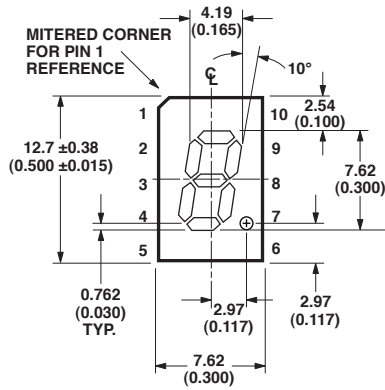

7.6 mm (0.3") Micro Bright Overflow Displays (Right Decimal Point) Package Dimension

Part Number	
HDSP-	7507
	A407
	7407
	7807
	7508
	A408
	7408
	7808

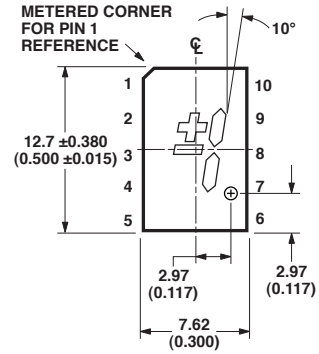

7.6 mm (0.3") Micro Bright Low Current Displays (Right Decimal Point) Package Dimension

Part Number		
HDSP-	A101	A111
	7511	A113
	A801	
	A901	
	A103	
	7513	
	A803	
A903		

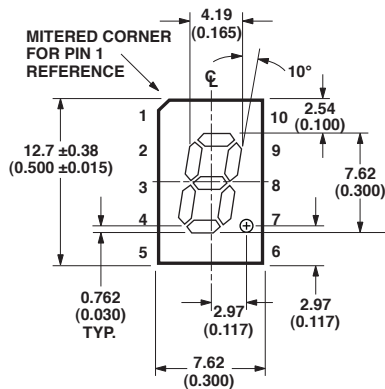

7.6 mm (0.3") Single Digit Displays Package Dimension

Part Number	
5802-	7610
	7611
	7613
	7620
	7621
	7623
	3600
	3601
	3603

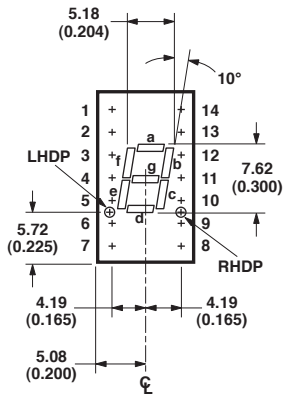

7.6 mm (0.3") Overflow Displays Package Dimension

Part Number	
5802-	7616
	7626
	3606

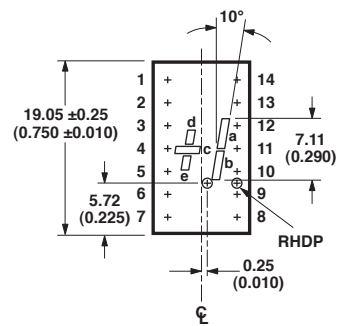

DIMENSIONS ARE IN MILLIMETERS (INCHES)

LED Indicators and Displays

Through-hole Seven-Segment Displays—Leadframe Platform

8 mm (0.31") Micro Bright Displays Package Dimension

Part Number	
HDSP-	Uxxx

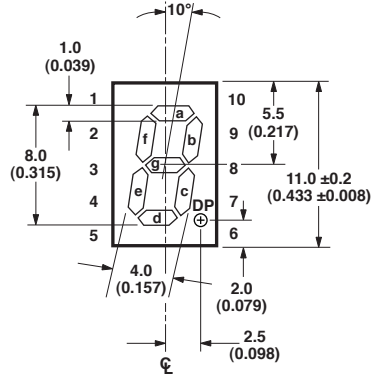

10 mm (0.4") Single Digit Displays (Right Decimal Point) Package Dimension

Part Number		
HDSP-	F111	F113
	F211	F213
	F511	F513
	F101	F103
	F201	F203
	F401	F403
	F411	F413
	F301	F303
	F501	F503
	F511	F513

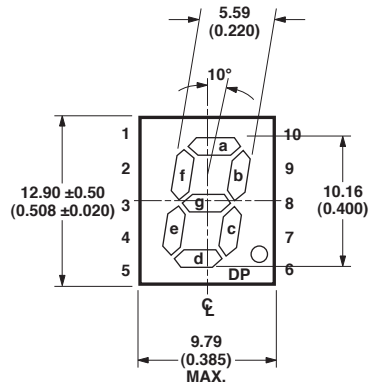

10 mm (0.4") Overflow Displays (Right Decimal Point) Package Dimension

Part Number		
HDSP-	F107	F108
	F207	F208
	F407	F408
	F307	F308
	F507	F508

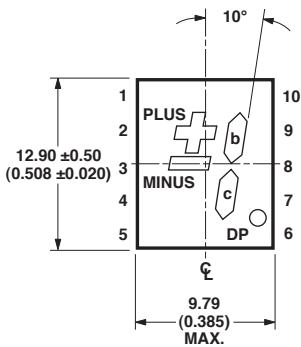

DIMENSIONS ARE IN MILLIMETERS (INCHES)

10 mm (0.4") Dual Digit Displays (Right Decimal Point) Package Dimension

Part Number		
HDSP-	G101	G103
	G111	G113
	G201	G203
	G211	G213
	G301	G303
	G401	G403
	G411	G413
	G501	G503
	G511	G513

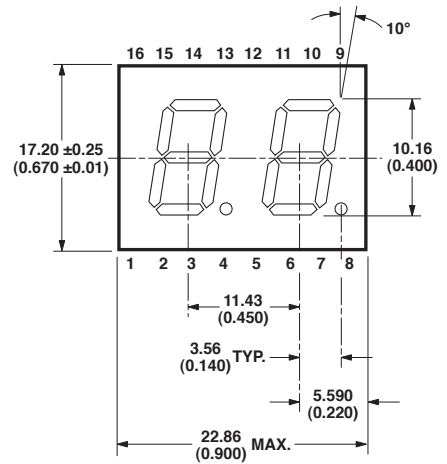

LED Indicators and Displays

Through-hole Seven-Segment Displays—Leadframe Platform

10.9 mm (0.43") Single Digit Displays (Right Decimal Point) Package Dimension

Part Number		
HDSP-	E101	E103
	3351	3353
5082-	7651	7653
	7661	7663
	4601	4603

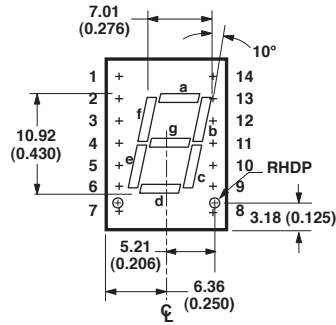

Part Number	
5802-	7650
	7660
	4600

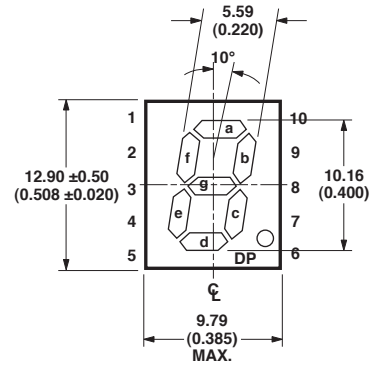

10.9 mm (0.43") Single Digit Displays Package Dimension

Part Number	
HDSP-	3350

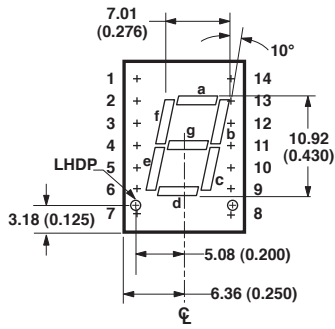

10.9 mm (0.43") Dual Digit Displays Package Dimension

Part Number		
HDSP-	G101	G103
	G201	G203
	G301	G303
	G401	G403
	G501	G503

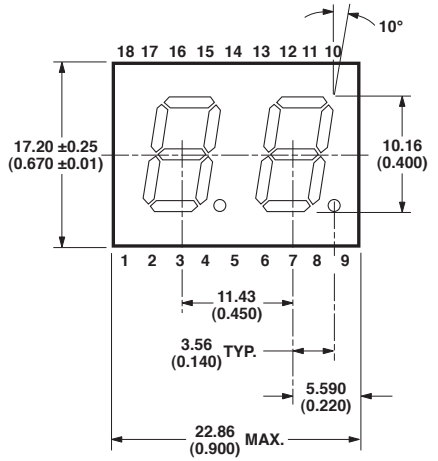

10.9 mm (0.43") Overflow Displays Package Dimension

Part Number		
HDSP-	4606	
5082-	7656	7666

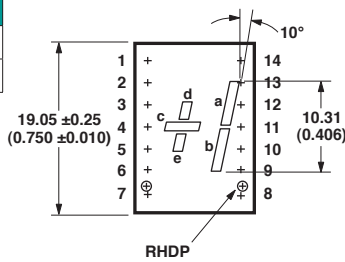

Part Number		
HDSP-	E106	3356

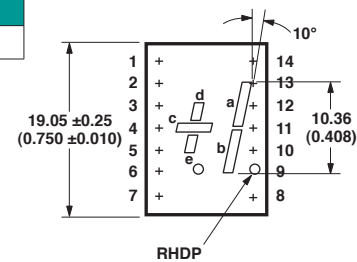

DIMENSIONS ARE IN MILLIMETERS (INCHES)

LED Indicators and Displays

Through-hole Seven-Segment Displays—Leadframe Platform

13 mm (0.56") Slim Font Displays Package Dimension

Part Number		
HDSP-	515H	516H
	515E	516E
	515L	516L
	515Y	516Y
	515G	516G
	56xE	56xG
	56xA	56xY

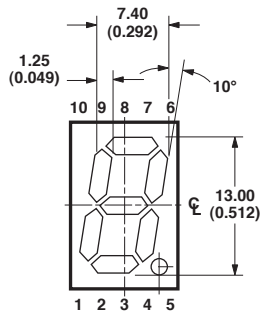

14.2 mm (0.56") Single Digit Displays (Right Decimal Point) Package Dimension

Part Number		
HDSP-	H111	H211
	H411	H511
	H113	H213
	H413	H513
	H101	H103
	H401	H403
	5551	5553
	5501	5503
	5701	5703
	5601	5603

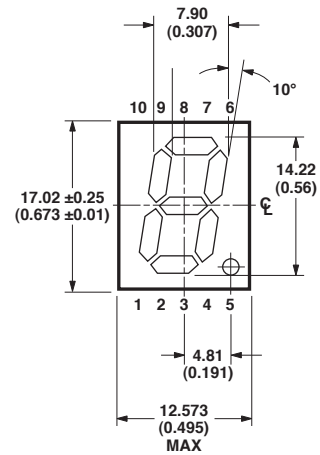

14.2 mm (0.56") Overflow Displays (Right Decimal Point) Package Dimension

Part Number		
HDSP-	H107	H108
	H407	H408
	5557	5558
	5507	5508
	5707	5708
	5607	5608

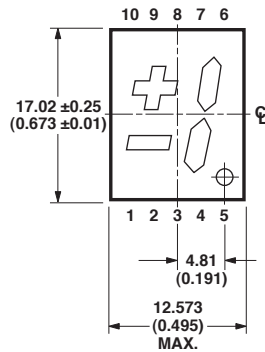

14.22 mm (0.56") Single Digit Displays Package Dimension

Part Number		
HDSP-	51xE	51xG
	51xA	51xY

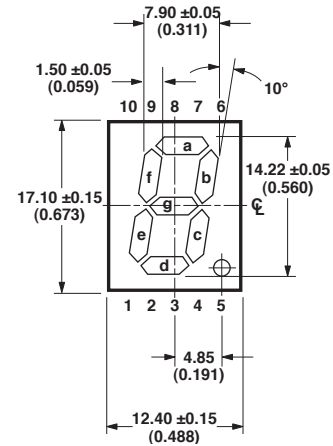

20 mm (0.8") Single Digit Overflow Displays Package Dimension

Part Number		
HDSP-	N106	N406
	3906	4206
	8606	

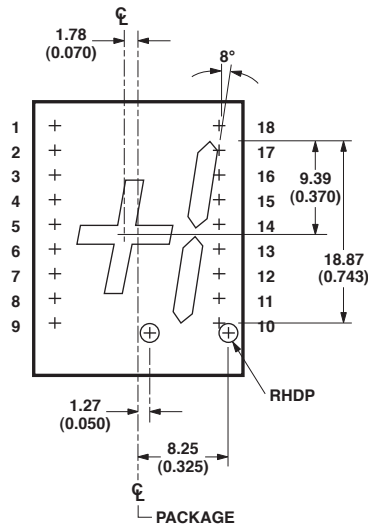

DIMENSIONS ARE IN MILLIMETERS (INCHES)

LED Indicators and Displays

Through-hole Seven-Segment Displays—Leadframe Platform cont.

20 mm (0.8") Single Digit Displays Package Dimension

Part Number		
HDSP-	3901	3903
	4201	4203
	8601	8603
	N101	N103
	N401	N403

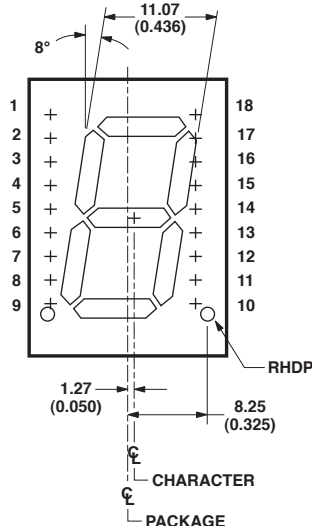

Part Number		
HDSP-	N100	N105
	3900	3905
	4200	4205
	8600	8605

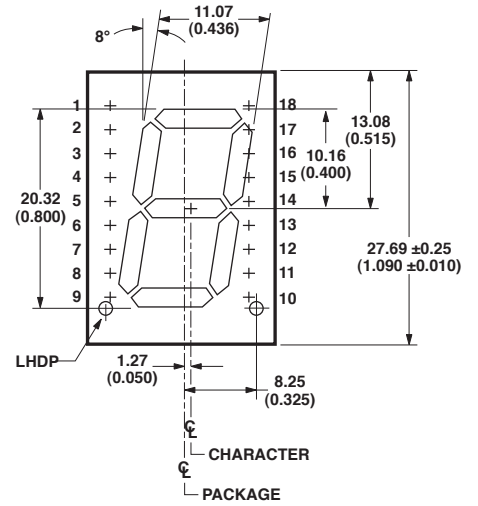

Through-hole Seven Segment Displays—PCB Platform

7.62 mm (0.3") Single Digit Displays Package Dimension

Part Number		
HDSP-	331E	331A
	331G	331Y

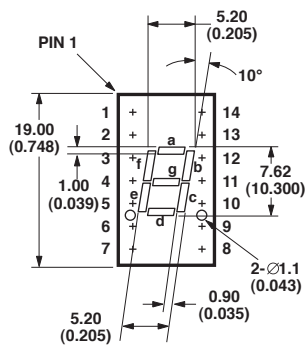

Part Number		
5802-	333E	334E
	333G	334G
	333A	334A
	333Y	334Y

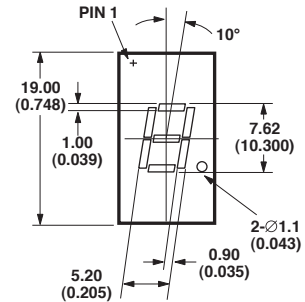

10 mm (0.4") Slim Font Single Digit Displays (Right Decimal Point) Package Dimension

Part Number		
HDSP-	315E	316E
	315L	316L
	315Y	316Y
	315G	316G
	30xE	30xG
	30xA	30xY

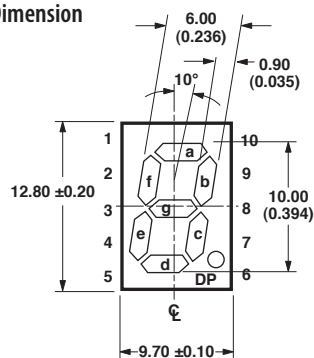

10.16 mm (0.4") Dual Digit Displays Package Dimension

Part Number		
HDSP-	G0xE	G0xG
	G0xA	G0xY

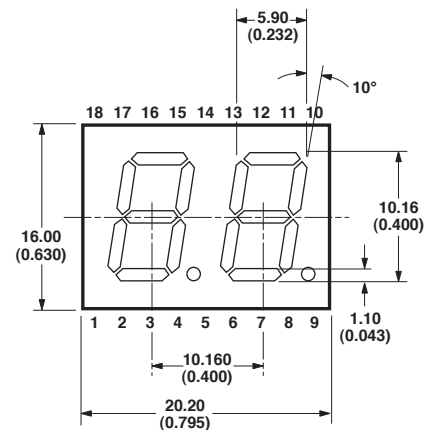

DIMENSIONS ARE IN MILLIMETERS (INCHES)

LED Indicators and Displays

Through-hole Seven Segment Displays—PCB Platform

10.16 mm (0.4") Single Digit Displays Package Dimension

Part Number	
HDSP-	311E
	311G
	311A
	311Y

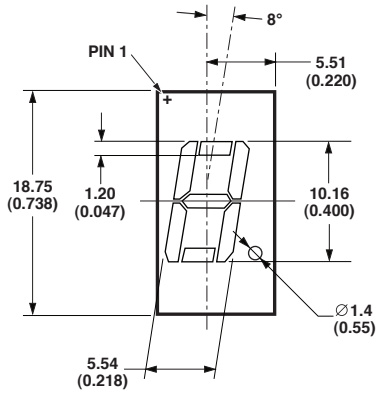

Part Number	
HDSP-	313E
	313G
	313A
	313Y

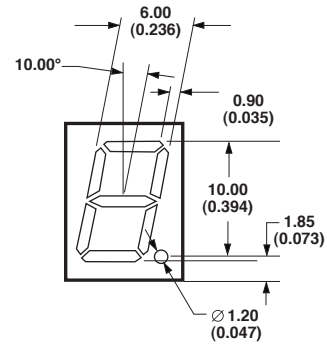

14.2 mm (0.56") Single Digit Displays (Right Decimal Point) Package Dimension

Part Number	
HDSP-	50xB

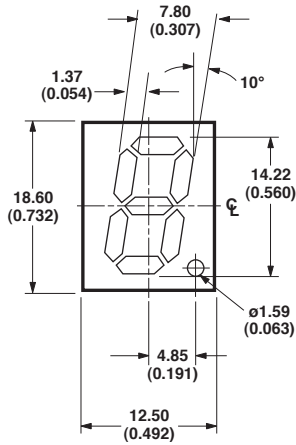

14.2 mm (0.56") Dual Digit Displays Package Dimension

Part Number			
HDSP-	52xA	52xE	
	52xG	52xY	

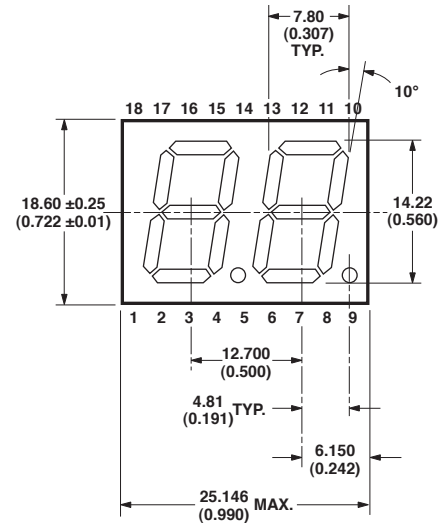

DIMENSIONS ARE IN MILLIMETERS (INCHES)

20 mm (0.8") Single Digit Displays Package Dimension

Part Number		
HDSP-	81xE	81xG

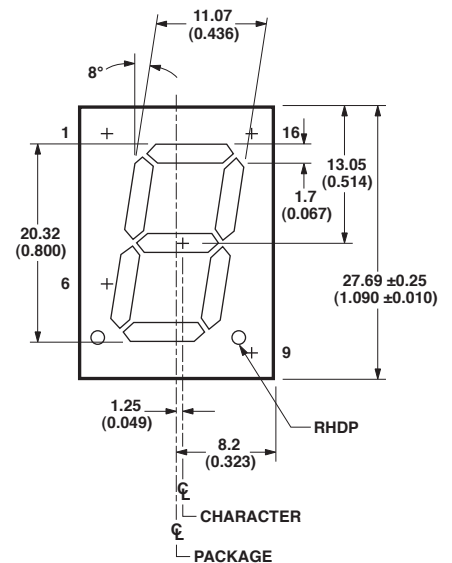

LED Indicators and Displays

Surface Mount Seven Segment Displays —PCB Platform

7.0mm (0.28") Single Digit SMT Display Package Dimension

Part Number	
HDSM-	281C
	281B
	283B
	283C
	281H
	283H
	281F
	283F
	281L
	283L

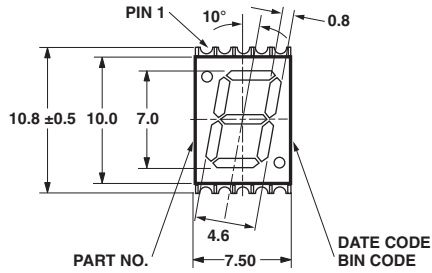

10.0mm (0.39") Dual Digit SMT Display Package Dimension

Part Number	
HDSM-	441C
	441B
	443B
	441W
	443W
	443C
	441H
	443H
	441F
	443F
	441L
	443L

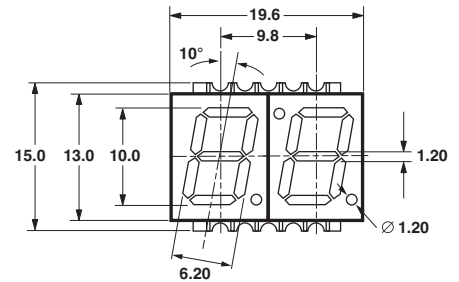

7.0mm (0.28") Dual Digit SMT Display Package Dimension

Part Number	
HDSM-	291C
	291B
	293B
	293C
	291H
	293H
	291F
	293F
	291L
	293L

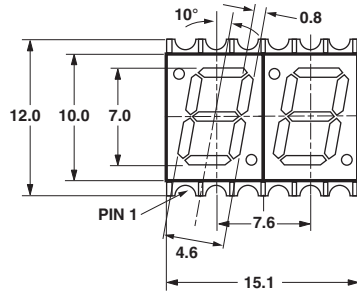

14.22mm (0.56") Single Digit SMT Display Package Dimension

Part Number	
HDSM	531C
	531B
	533B
	531W
	533W
	533C
	531H
	533H
	531F
	533F
	531L
	533L

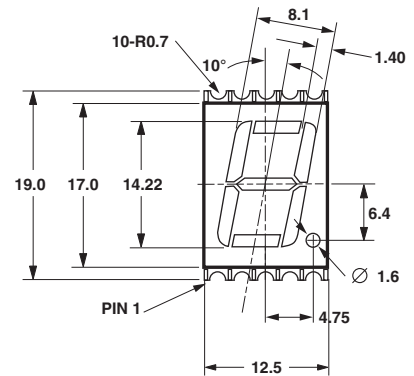

10mm (0.39") Single Digit SMT Display Package Dimension

Part Number	
HDSM	431C
	431B
	433B
	431W
	433W
	433C
	431H
	433H
	431F
	433F
	431L
	433L

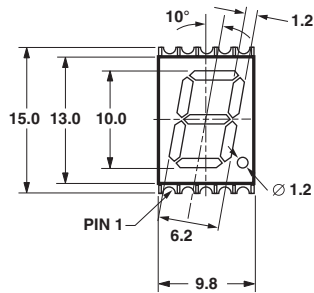

14.22mm (0.56") Dual Digit SMT Display Package Dimension

Part Number	
HDSM-	541C
	541B
	543B
	541W
	543W
	543C
	541H
	543H
	541F
	543F
	541L
	543L

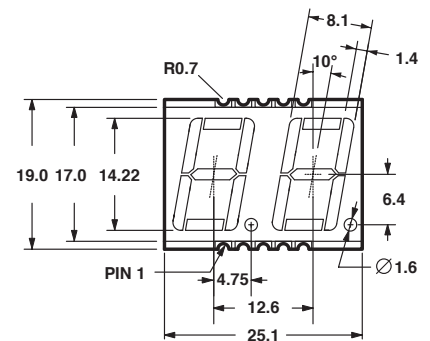

Light Bars and Bar Graph Arrays

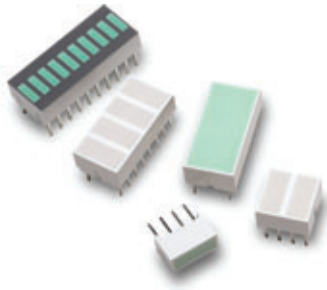

Description — Light Bars

Light Bars are Avago Technologies' innovative solution to fixed message annunciation. They are used as annunciators that serve three customer functions: status indication, backlighting fixed messages and analog level indications (arrays). The Light Bars provide exceptional brightness at very low drive current for those applications where portability and battery backup are vital. These rectangular light sources are configured in single-in-line and dual-in-line packages that contain either single or segmented light emitting areas. They are also X-Y stackable.

Features & Benefits

- Large, bright, uniform light emitting surface
- Yellow and green categorized for dominant wavelength
- Low heat dissipation
- Choices of colors — Red, Green, Yellow
- Various package sizes are X-Y stackable
- Industry standard SIP and DIP packages

Typical Applications

- Business machines
 - Point of sale bar code scanner
 - Electronic typewriters
 - Fax machines
 - Electronic scales
 - Postal meters
- Instrumentation
 - Process control system
 - Medical equipment
 - Machine control systems
 - Meters and status indicators
- Telecommunications
 - PBX systems
 - Modems
 - Central switching systems
 - Diagnostic equipment
 - Short wave radios
- Transportation
 - Automotive dashboards
 - Truck and bus controls
 - Airport passenger metal detectors
 - Ticket vending machines
- Consumer
 - Appliance front panel
 - Hi-Fi/stereo equipment
 - Alarm system

Description — 10-Element Bar Graph Arrays

Avago Technologies' 10-Element Bar Graph Arrays serve a market need for analog level indication. LED reliability, light emitting viewability make them suitable in place of mechanical meters. They are designed to display information in easily recognizable bar graph form. The packages are end stackable and are therefore capable of displaying long strings of information. The bar graph arrays are precision matched for both intensity and wavelength, saving you the time and trouble of matching individual parts. The prealigned bar graph elements locked in a single package eliminates the task of matching and aligning individual LEDs during manufacturing, along with the risk of visually substandard front panels resulting from misaligned indicators. Each device offers easy-to-handle packages that are compatible with standard DIP sockets.

Features & Benefits

- Exclusive package interlock
 - Facilitate end stacking alignment
- Large segment size
 - Wide viewing angle
- Available in Red, Green, Yellow and multicolor
- Wide variety of applications
- Categorized and packaged for luminous intensity
 - Greater uniformity of light output
- Matched LEDs for uniform appearance

Typical Applications

- Instrumentation
 - Meters
 - Channel indicators
 - Status indicators
- Process control
 - Level indicators
- Appliances
 - Status of indication
 - Mode of operation
- Transportation
 - Tachometers
 - Fuel gauges
- Consumer products
 - VU meters (stereos)
 - Radio channel scanners
 - Burglar alarms

LED Indicators and Displays

Light Bars

Shape	Size/# Light Emitting	Part Number	Color	Chip (nm) Typ.	Vf (V) Typ.	Vf (V) at If = mA	Iv at If = mA	Iv Min. (mcd)	Iv Typ. (mcd)	2 Intensity Bin Selection
0.4SIP	0.35" x 0.15" 1 area	HLCP-A100	AlGaAs Red	637	1.8	20	3	3	7.5	B, C
0.4SIP	0.35" x 0.15" 1 area	HLMP-2300	GaP Red	626	2	20	20	6	23	E, F
0.4SIP	0.35" x 0.15" 1 area	HLMP-2400	GaP Yellow	585	2.1	20	20	6	20	E, F
0.4SIP	0.35" x 0.15" 1 area	HLMP-2500	GaP Green	572	2.2	20	20	5	25	F, G
0.8SIP	0.75" x 0.15" 1 area	HLCP-B100	AlGaAs Red	637	1.8	20	3	6	15	B, C
0.8SIP	0.75" x 0.15" 1 area	HLMP-2350	GaP Red	626	2	20	20	13	45	E, F
0.8SIP	0.75" x 0.15" 1 area	HLMP-2450	GaP Yellow	585	2.1	20	20	13	38	E, F
0.8SIP	0.75" x 0.15" 1 area	HLMP-2550	GaP Green	572	2.2	20	20	11	50	F, G
0.4DIP	0.35" x 0.35" 1 area	HLCP-C100	AlGaAs Red	637	1.8	20	3	6	15	—
0.4DIP	0.35" x 0.35" 1 area	HLMP-2655	GaP Red	626	2	20	20	13	45	E, F
0.4DIP	0.35" x 0.35" 1 area	HLMP-2755	GaP Yellow	585	2.1	20	20	13	38	E, F
0.4DIP	0.35" x 0.35" 1 area	HLMP-2855	GaP Green	572	2.2	20	20	11	50	F, G
0.4DIP	0.35" x 0.15" 2 areas	HLCP-D100	AlGaAs Red	637	1.8	20	3	3	7.5	B, C
0.4DIP	0.35" x 0.15" 2 areas	HLMP-2600	GaP Red	626	2	20	20	6	23	E, F
0.4DIP	0.35" x 0.15" 2 areas	HLMP-2700	GaP Yellow	585	2.1	20	20	6	20	E, F
0.4DIP	0.35" x 0.15" 2 areas	HLMP-2800	GaP Green	572	2.1	20	20	5	25	—
0.8DIP	0.35" x 0.15" 4 areas	HLCP-E100	AlGaAs Red	637	1.8	20	3	3	7.5	B, C
0.8DIP	0.35" x 0.15" 4 areas	HLMP-2620	GaP Red	626	2	20	20	6	23	E, F
0.8DIP	0.35" x 0.15" 4 areas	HLMP-2720	GaP Yellow	585	2.1	20	20	6	20	E, F
0.8DIP	0.35" x 0.15" 4 areas	HLMP-2820	GaP Green	572	2.2	20	20	5	25	F, G
0.8DIP	0.15" x 0.75" 2 areas	HLCP-F100	AlGaAs Red	637	1.8	20	3	6	15	—
0.8DIP	0.15" x 0.75" 2 areas	HLMP-2635	GaP Red	626	2	20	20	13	45	—
0.8DIP	0.15" x 0.75" 2 areas	HLMP-2735	GaP Yellow	585	2.1	20	20	13	38	—
0.8DIP	0.15" x 0.75" 2 areas	HLMP-2835	GaP Green	572	2.2	20	20	11	50	—
0.8DIP	0.35" x 0.35" 2 areas	HLCP-G100	AlGaAs Red	637	1.8	20	3	6	15	—
0.8DIP	0.35" x 0.35" 2 areas	HLMP-2670	GaP Red	626	2	20	20	13	45	—
0.8DIP	0.35" x 0.35" 2 areas	HLMP-2770	GaP Yellow	585	2.1	20	20	13	38	—
0.8DIP	0.35" x 0.35" 2 areas	HLMP-2870	GaP Green	572	2.2	20	20	11	50	F, G
0.8DIP	0.35" x 0.75" 1 areas	HLCP-H100	AlGaAs Red	637	1.8	20	3	12	30	B, C
0.8DIP	0.35" x 0.75" 1 areas	HLMP-2685	GaP Red	626	2	20	20	22	80	—
0.8DIP	0.35" x 0.75" 1 areas	HLMP-2785	GaP Yellow	585	2.1	20	20	26	70	E, F
0.8DIP	0.35" x 0.75" 1 areas	HLMP-2885	GaP Green	572	2.2	20	20	22	100	F, G

LED Indicators and Displays

Bicolor Light Bars







Shape	Size/# Light Emitting	Part Number	Color	Chip (nm) Typ.	Vf (V) Typ.	Vf (V) at If = mA	Iv at If = mA	Iv Min. (mcd)	Iv Typ. (mcd)	2 Intensity Bin Selection
0.4DIP	0.35" x 0.35" 1 area	HLMP-2950	GaP Red	626	2	20	20	13	45	–
			GaP Yellow	585	2.1	20	20	13	38	–
0.4DIP	0.35" x 0.35" 1 area	HLMP-2965	GaP Red	626	2	20	20	19	45	–
			GaP Green	572	2.2	20	20	25	50	–



Bar Graph Arrays

10 Element	HLCP-J100	AlGaAs Red	637	1.6	1	1	600	1000	–
	HDSP-4830	GaP Red	626	2.1	20	10	900	3500	G, H
	HDSP-4840	GaP Yellow	585	2.2	20	10	600	1900	F, G
	HDSP-4850	GaP Green	572	2.1	10	10	600	1900	H, I
Multicolor LA	HDSP-4832	GaP Red	626	2.1	20	10	600	3500	–
		GaP Yellow	585	2.2	20	10	600	1900	–
		GaP Green	572	2.1	10	10	600	1900	–
	HDSP-4836	GaP Red	626	2.1	20	10	600	3500	–
		GaP Yellow	585	2.2	20	10	600	1900	–
		GaP Green	572	2.1	10	10	600	1900	–
		GaP Yellow	585	2.2	20	10	600	1900	–
		GaP Red	626	2.1	20	10	600	3500	–





Luminous Intensity Categories

LED Light Bars





Bin ID	Customer Iv in mcd	
	Min.	Max.
AlGaAs Red 	HLCP-A100 / D100 / E100	
GaP Red 	HLMP-2300 / 2600 / 2620	
B	4.5	8.2
C	6.8	12.1
D	10.1	18.5
E	15.3	27.8
F	22.8	45.5
AlGaAs Red 	HLCP-B100 / C100 / F100 / G100	
GaP Red 	HLMP-2350 / 2635 / 2655 / 2670	
B	9.0	16.0
C	13.1	24.0
D	19.7	36.1
E	29.6	54.2
F	44.9	88.8
AlGaAs Red 	HLCP-H100	
GaP Red 	HLMP-2685	
B	18.0	27.1
C	22.0	40.8
D	33.3	61.1
E	50.0	91.8
F	75.1	150.0

Bin ID	Customer Iv in mcd	
	Min.	Max.
GaP Yellow 	HLMP-2400 / 2700 / 2720	
E	13.8	25.3
F	20.7	41.4
HLMP-2450 / 2735 / 2755 / 2770		
E	27.0	50.0
F	40.5	81.0
HLMP-2785		
E	54.0	99.0
F	81.0	162.0
GaP Green 	HLMP-2500 / 2800 / 2820	
F	18.9	37.8
G	30.6	61.2
HLMP-2550 / 2835 / 2855 / 2870		
F	38.1	76.2
G	61.6	123.2
HLMP-2885		
F	75.1	150.3
G	121.1	242.2

Bicolor Light Bars

Bin ID	Customer Iv in mcd	
	Min.	Max.
HLMP-2950/GaP Red 		
D	17.00	31.00
E	25.40	46.50
F	38.10	76.20
GaP Yellow 		
D	18.00	33.00
E	27.00	50.00
F	40.50	81.00
HLMP-2965/GaP Red 		
F	44.90	88.80
G	71.90	143.80
GaP Green 		
F	38.10	76.20
G	61.60	123.20

Bar Graph Arrays

Bin ID	Customer Iv in mcd	
	Min.	Max.
AlGaAs Red / HLCP-J100 		
GaP Red / GaP Yellow / GaP Green   		
HDSP-4830 / 4840 / 4850		
D	0.61	1.11
E	0.91	1.67
F	1.37	2.51
G	2.05	3.76
H	3.08	5.64
I	4.62	8.64

LED Indicators and Displays

LED Light Bar and Bar Graph Array Package Dimension Drawings

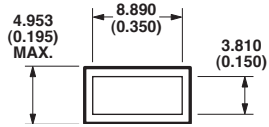

HLCP-A100
HLMP-2300/2400/2500

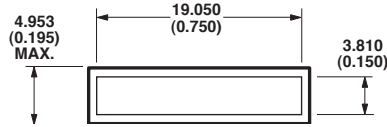

HLCP-B100
HLMP-2x50

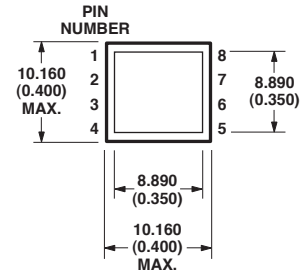

HLCP-C100
HLMP-2x55

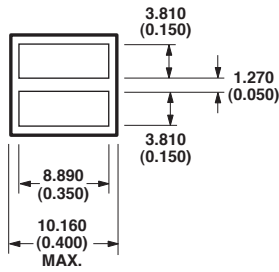

HLCP-D100
HLMP-2600/2700/2800

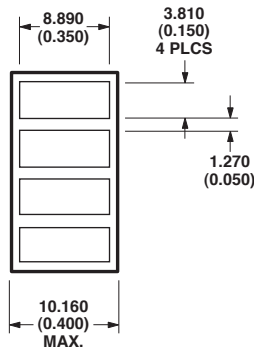

HLCP-E100
HLMP-2x20

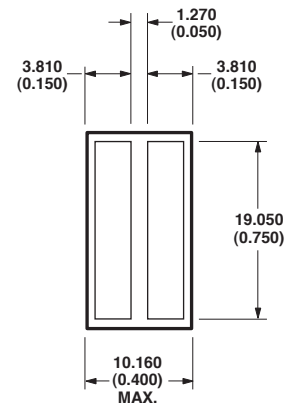

HLCP-F100
HLMP-2x35

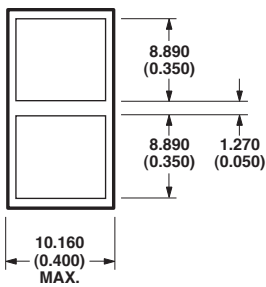

HLCP-G100
HLMP-2x70

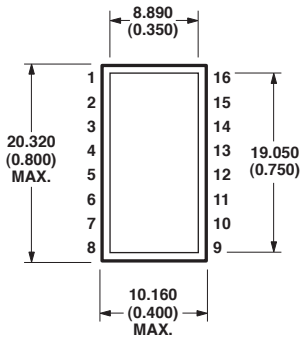

HLCP-H100
HLMP-2x85

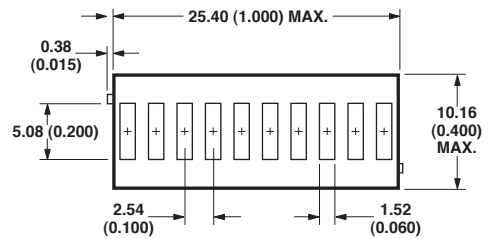

HLCP-J100
HDSP-48x0

DIMENSIONS ARE IN MILLIMETERS (INCHES)

Smart Displays

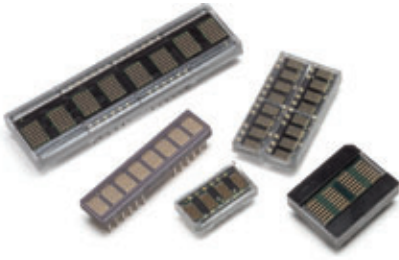

Description

Avago Technologies offers high quality Smart Displays to meet a wide range of applications and requirements. The Smart Displays are available in both serial and parallel interface and have an ASIC driver that greatly simplifies design efforts. The Smart Displays are LED technology-based and are extremely reliable with a long life expectancy. They are resistant to extreme weather conditions, and to mechanical vibration and shock, making them suitable for industrial applications where maintenance resources are scarce. They are also suitable for the consumer market where the need for aesthetics and product differentiation provides a competitive advantage to our customers' end products. Avago Technologies' Smart Display products are positioned to support high volume and cost-effective solutions.

Features and Benefits

- Robust design for high reliability, longer life and hot and cold temperature operating capability
 - Ideally suited for outdoor, industrial and automotive applications
- Alphanumeric characters and custom icons for messaging
 - Useful for conveying operating modes, status, warning and error codes
- Ability to flash or blink
 - Catch user's attention
- ASIC LED driver
 - Simplified design interfacing reduces design cycle time
- Emissive display with brightness control
 - Ability to modify brightness for subdued light environment and total darkness
- Aesthetically pleasing
 - Distinctive display allows product differentiation

Typical Applications

- Industrial Equipment
 - Industrial ovens, reliability test equipment, analytical instruments, process control equipment, test and measuring instruments, temperature controllers, programmable logic controllers, security systems
- Networking
 - Telecommunication equipment, answering machines, telephones, base stations, PBX modems, network cards
- Outdoor Signs
 - Petrol pump meters
- Consumer
 - Audio/video equipment, audio mixers, set top boxes, amplifiers, musical instruments, gaming machines, currency/coin counters, security systems
- Consumer "White Goods"
 - Displays for washing machine digital panels, cookers, freezers and dishwashers
- Medical Equipment
 - Hospital monitoring systems
- Transportation
 - Displays, radar detectors, avionics displays
- Computers and Peripherals
 - CPU speed indicator, printer front panels, fax machines, copy machines, power supply equipment, cash registers

LED Indicators and Displays

Plastic Package, Serial Interface, 5 x 7 Dot Matrix Display with Custom Font Programmable

Part Number	Character	Color	Interface	Character Height (mm)	Intensity, Typ. (μcd)	Supply, Typ. (mA)
HCMS-2901	4	Yellow	Serial	3.7	64	132
HCMS-2902	4	Red	Serial	3.7	64	132
HCMS-2903	4	Green	Serial	3.7	114	132
HCMS-2904	4	Orange	Serial	3.7	64	132
HCMS-2905	4	AlGaAs Red	Serial	3.7	230	145
HCMS-2911	8	Yellow	Serial	3.7	64	264
HCMS-2912	8	Red	Serial	3.7	64	264
HCMS-2913	8	Green	Serial	3.7	114	264
HCMS-2914	8	Orange	Serial	3.7	64	264
HCMS-2915	8	AlGaAs Red	Serial	3.7	230	290
HCMS-2919	8	Blue	Serial	3.7	170	264
HCMS-2921	16	Yellow	Serial	3.7	64	528
HCMS-2922	16	Red	Serial	3.7	64	528
HCMS-2923	16	Green	Serial	3.7	114	528
HCMS-2924	16	Orange	Serial	3.7	64	528
HCMS-2925	16	AlGaAs Red	Serial	3.7	230	580
HCMS-2961	4	Yellow	Serial	4.6	64	132
HCMS-2962	4	Red	Serial	4.6	64	132
HCMS-2963	4	Green	Serial	4.6	114	132
HCMS-2964	4	Orange	Serial	4.6	64	132
HCMS-2965	4	AlGaAs Red	Serial	4.6	230	145
HCMS-2971	8	Yellow	Serial	4.6	64	264
HCMS-2972	8	Red	Serial	4.6	64	264
HCMS-2973	8	Green	Serial	4.6	114	264
HCMS-2974	8	Orange	Serial	4.6	64	264
HCMS-2975	8	AlGaAs Red	Serial	4.6	230	290
HCMS-3901	4	Yellow	Serial	3.7	148	132
HCMS-3902	4	Red	Serial	3.7	64	132
HCMS-3903	4	Green	Serial	3.7	252	132
HCMS-3904	4	Orange	Serial	3.7	64	132
HCMS-3906	4	Red	Serial	3.7	1150	132
HCMS-3907	4	Green	Serial	3.7	500	132
HCMS-3911	8	Yellow	Serial	3.7	148	264
HCMS-3912	8	Red	Serial	3.7	64	264
HCMS-3913	8	Green	Serial	3.7	252	264
HCMS-3914	8	Orange	Serial	3.7	64	264
HCMS-3916	8	Red	Serial	3.7	1150	264
HCMS-3917	8	Green	Serial	3.7	500	264
HCMS-3961	4	Yellow	Serial	4.6	148	132
HCMS-3962	4	Red	Serial	4.6	64	132
HCMS-3963	4	Green	Serial	4.6	252	132
HCMS-3964	4	Orange	Serial	4.6	64	132
HCMS-3966	4	Red	Serial	4.6	1150	132
HCMS-3967	4	Green	Serial	4.6	500	132
HCMS-3971	8	Yellow	Serial	4.6	148	264
HCMS-3972	8	Red	Serial	4.6	64	264
HCMS-3973	8	Green	Serial	4.6	252	264
HCMS-3974	8	Orange	Serial	4.6	64	264
HCMS-3976	8	Red	Serial	4.6	1150	264
HCMS-3977	8	Green	Serial	4.6	500	264

Notes:

Typical values at T_A = 25°C.

Luminous intensity for one pixel at V_{LED} = 5.0 V, 50% peak pixel current, 100% pulse width.

Supply current at V_{LED} = 5.0V, 100% peak pixel current, 100% pulse width, 20 pixels per digit at all digit locations.

LED Indicators and Displays

Plastic Package, Serial Interface, 5 x 7 Dot Matrix Display with Custom Font Programmable

Part Number	Character	Color	Interface	Character Height (mm)	Intensity, Typ. (μcd)	Supply, Typ. (mA)
HDLY-1414	4	Yellow	Parallel	3.6	3.7	110
HDLO-1414	4	Red	Parallel	3.6	3.5	110
HDLG-1414	4	Green	Parallel	3.6	5.6	110
HDLA-1414	4	Orange	Parallel	3.6	3.5	110
HDLU-1414	4	AlGaAs Red	Parallel	3.6	3.1	34
HDLS-1414	4	AlGaAs Red	Parallel	3.6	12.7	125
HDLY-2416	4	Yellow	Parallel	5.1	3.7	110
HDLO-2416	4	Red	Parallel	5.1	3.5	110
HDLG-2416	4	Green	Parallel	5.1	5.6	110
HDLA-2416	4	Orange	Parallel	5.1	3.5	110
HDLU-2416	4	AlGaAs Red	Parallel	5.1	3.1	34
HDLS-2416	4	AlGaAs Red	Parallel	5.1	12.7	125
HDLY-3416	4	Yellow	Parallel	6.9	3.7	110
HDLO-3416	4	Red	Parallel	6.9	3.5	110
HDLG-3416	4	Green	Parallel	6.9	5.6	110
HDLA-3416	4	Orange	Parallel	6.9	3.5	110

Plastic Package, Parallel Interface, 8 Character, 5 x 7 Dot Matrix Display with 128 Character ASCII Decoder

Part Number	Character	Color	Interface	Character Height (mm)	Intensity, Typ. (μcd)	Supply, Typ. (mA)
HDSP-2530	8	Orange	Parallel	4.6	7.5	300
HDSP-2531	8	Yellow	Parallel	4.6	7.	300
HDSP-2532	8	Red	Parallel	4.6	7.5	300
HDSP-2533	8	Green	Parallel	4.6	7.5	300
HDSP-2534	8	AlGaAs Red	Parallel	4.6	15	330
HDSP-2110	8	Orange	Parallel	4.8	7.5	300
HDSP-2111	8	Yellow	Parallel	4.8	7.5	300
HDSP-2112	8	Red	Parallel	4.8	7.5	300
HDSP-2113	8	Green	Parallel	4.8	7.5	300
HDSP-2107	8	AlGaAs Red	Parallel	4.8	15	330
HDSP-2500	8	Orange	Parallel	7.0	7.5	300
HDSP-2501	8	Yellow	Parallel	7.0	7.5	300
HDSP-2502	8	Red	Parallel	7.0	7.5	300
HDSP-2503	8	Green	Parallel	7.0	7.5	300
HDSP-2504	8	AlGaAs Red	Parallel	7.0	1.5	330

Notes:

Typical values at $V_{DD} = 5.0V$, $T_A = 25^\circ\text{C}$.

Luminous intensity at 100% full brightness, character average with “#” (20 pixels) displayed.

Supply current at 100% brightness, with all character locations displaying “#” (20 pixels).

LED Indicators and Displays

Glass/Ceramic Package, Parallel Interface, 8 Character, 5 x 7 Dot Matrix with 128 Character ASCII Decoder

Part Number	Character	Color	Interface	Character Height (mm)	Intensity, Typ. (μcd)	Supply, Typ. (mA)
HDSP-2131	8	Yellow	Parallel	4.8	7.5	300
HDSP-2132	8	Red	Parallel	4.8	7.5	300
HDSP-2133	8	Green	Parallel	4.8	7.5	300
HDSP-2179	8	Orange	Parallel	4.8	7.5	300

Notes:

Typical values at $V_{DD} = 5.0V$, $T_A = 25^\circ\text{C}$.

Luminous intensity at 100% full brightness, character average with “#” (20 pixels) displayed.

Supply current at 100% brightness, with all character locations displaying “#” (20 pixels).

Glass/Ceramic Package, 4 x 7 Hexadecimal Display with Built-in BCD Decoder/Driver

Part Number	Description/Decimal Point	Color	Operation Temperature ($^\circ\text{C}$)	Character Height (mm)	Luminous Intensity Typ. (μcd)	Supply Current Typ. (mA)
HDSP-0760	Numeric, RHDP	HER	-55 to 85	7.4	140	78
HDSP-0761	Numeric, LHDP	HER	-55 to 85	7.4	140	78
HDSP-0762	Hexadecimal	HER	-55 to 85	7.4	140	78
HDSP-0770	Numeric, RHDP	HER	-55 to 85	7.4	620	120
HDSP-0771	Numeric, LHDP	HER	-55 to 85	7.4	620	120
HDSP-0772	Hexadecimal	HER	-55 to 85	7.4	620	120
HDSP-0781	Numeric, RHDP	HER	-55 to 100	7.4	140	78
HDSP-0782	Numeric, LHDP	HER	-55 to 100	7.4	140	78
HDSP-0784	Hexadecimal	HER	-55 to 100	7.4	140	78
HDSP-0791	Numeric, RHDP	HER	-55 to 100	7.4	620	120
HDSP-0792	Numeric, LHDP	HER	-55 to 100	7.4	620	120
HDSP-0794	Hexadecimal	HER	-55 to 100	7.4	620	120
HDSP-0860	Numeric, RHDP	Yellow	-55 to 85	7.4	490	120
HDSP-0861	Numeric, LHDP	Yellow	-55 to 85	7.4	490	120
HDSP-0862	Hexadecimal	Yellow	-55 to 85	7.4	490	120
HDSP-0881	Numeric, RHDP	Yellow	-55 to 100	7.4	490	120
HDSP-0884	Hexadecimal	Yellow	-55 to 100	7.4	490	120
HDSP-0960	Numeric, RHDP	Green	-55 to 85	7.4	1100	120
HDSP-0961	Numeric, LHDP	Green	-55 to 85	7.4	1100	120
HDSP-0962	Hexadecimal	Green	-55 to 85	7.4	1100	120
HDSP-0981	Numeric, RHDP	Green	-55 to 100	7.4	1100	120
HDSP-0984	Hexadecimal	Green	-55 to 100	7.4	1100	120

Notes:

Typical values at $V_{DD} = 5.0V$, $T_A = 25^\circ\text{C}$.

Luminous intensity per LED (Digit Average).

Supply current with “5” or “B” character displayed.

Glass/Ceramic Package Over Range \pm with Built-in BCD Decoder/Driver

Part Number	Description/Decimal Point	Color	Operation Temperature ($^\circ\text{C}$)	Character Height (mm)	Luminous Intensity Typ. (μcd)	Supply Current Typ. (mA)
HDSP-0763	Overrange ± 1	HER	-55 to 85	7.4	140	11.2
HDSP-0863	Overrange ± 1	Yellow	-55 to 85	7.4	490	32
HDSP-0963	Overrange ± 1	Green	-55 to 85	7.4	1100	32

Notes:

Typical values at $V_{DD} = 5.0V$, $T_A = 25^\circ\text{C}$.

Luminous intensity per LED (Digit Average).

Glass/Ceramic Package, Serial Interface, 4 character, 5 x 7 Dot Matrix with 128 Character ASCII Decoder

Part Number	Character	COLOR	Interface	Character Height (mm)	Intensity, Typ. (μcd)	Supply, Typ. (mA)
HCMS-2351	4	Yellow	Serial	4.9	3400	6.2
HCMS-2353	4	Green	Serial	4.9	3000	6.2

Notes:

Typical values at $V_{DD} = 5.0V$, $T_A = 25^\circ\text{C}$.

Luminous intensity (peak) per LED (Digit Average).

LED Indicators and Displays

LED Dot Matrix Smart Displays Package Dimension Drawings

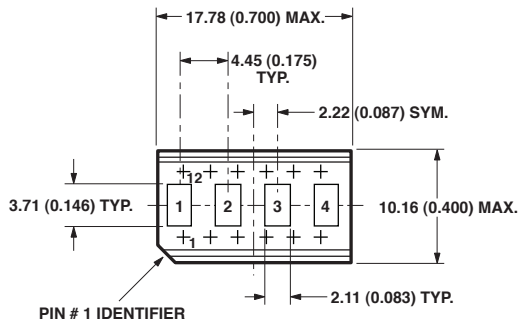

HCMS-290x/HCMS-390x

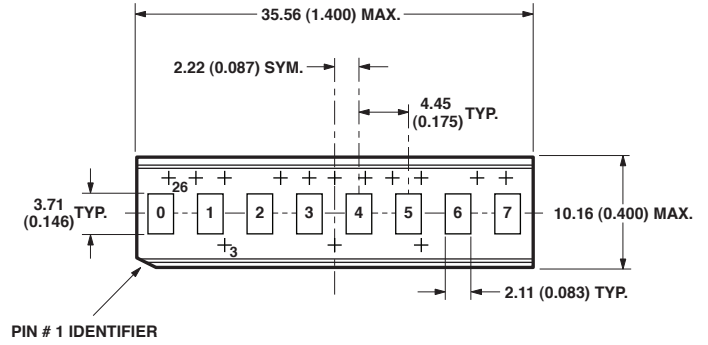

HCMS-291x/HCMS-391x

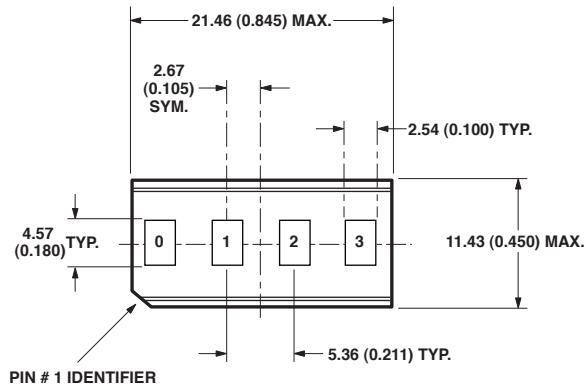

HCMS-296x/HCMS-396x

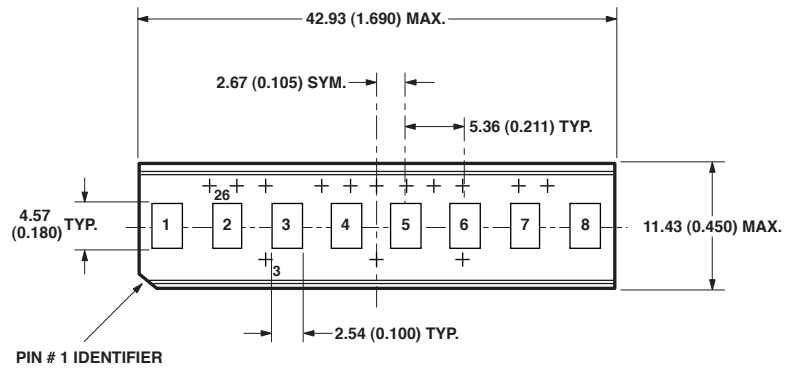

HCMS-297x/HCMS-397x

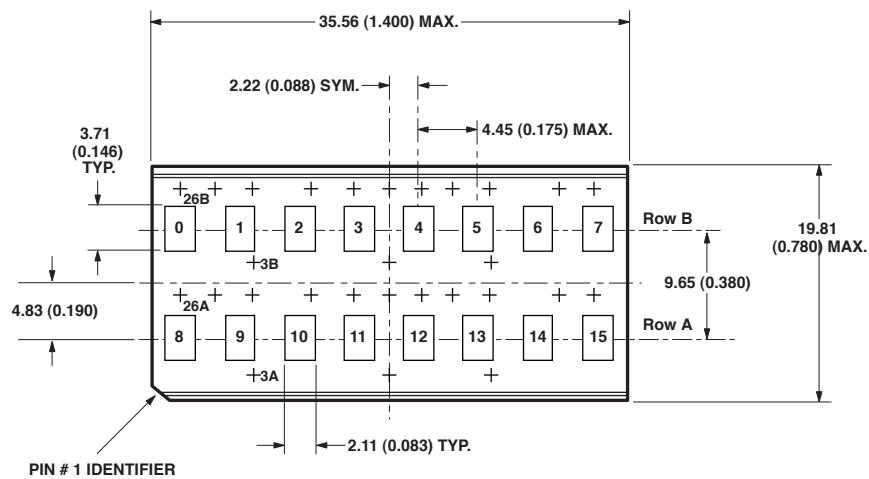

HCMS-292x

DIMENSIONS ARE IN MILLIMETERS (INCHES)

LED Indicators and Displays

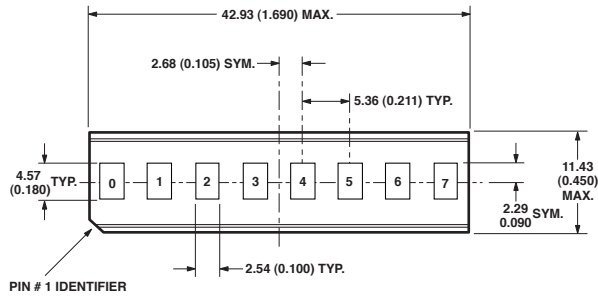

HDSP-253x

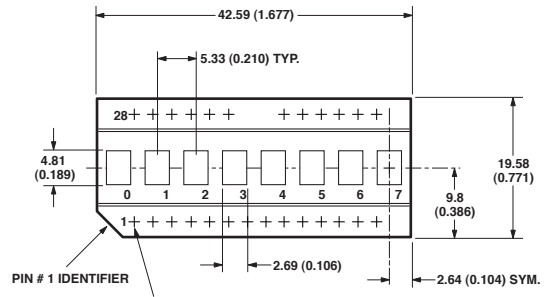

HDSP-2107,-211x

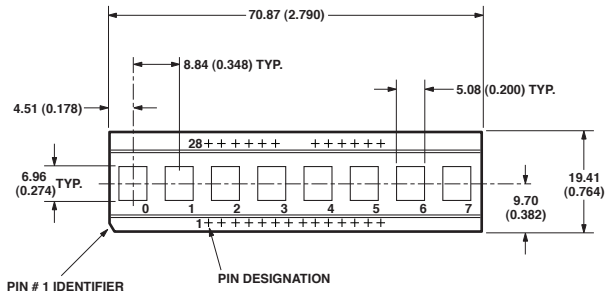

HDSP-250x

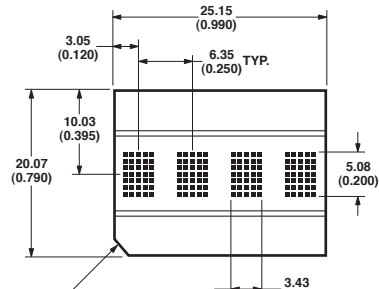

HDLx-2416

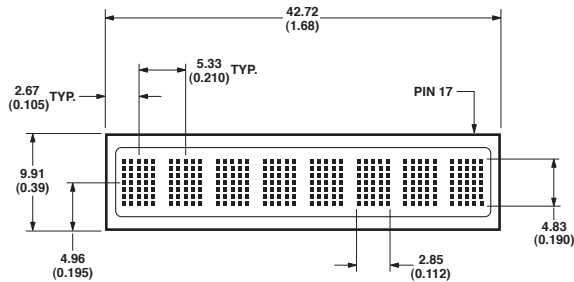

HDSP-213x,-2179

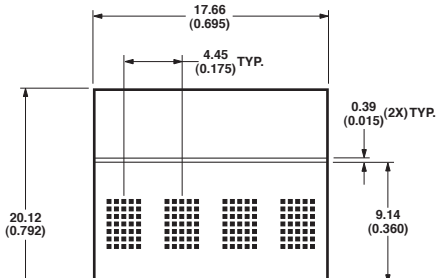

HDLx-1414

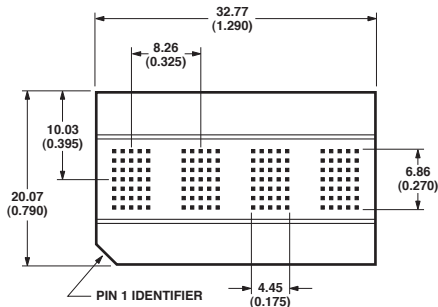

HDLx-3416

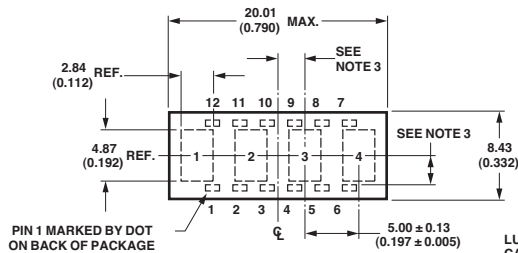

LUMINOUS INTENSITY CATEGORY

HDLx-3416

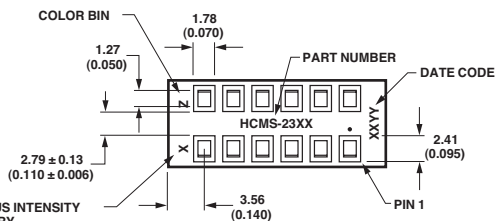

About Avago Technologies

Avago Technologies is a leading supplier of analog interface components for communications, industrial and consumer applications. By leveraging its core competencies in III-V compound and silicon semiconductor design and processing, the company provides an extensive range of analog, mixed signal and optoelectronics components and subsystems to more than 40,000 customers. Backed by strong customer service support, the company's products serve four diverse end markets: industrial and automotive, wired infrastructure, wireless communications, and computer peripherals. Avago has a global employee presence and heritage of technical innovation dating back 40 years to its Hewlett-Packard roots. Information about Avago is available on the Web at www.avagotech.com

For product information and a complete list of distributors,
please go to our web site:

www.avagotech.com
www.avagotech.com/led

For technical support please email a Technical Response Center in
your region:

United States: support@avagotech.com

Europe: info@promotionteam.de

Asia Pacific: pacrim.components@avagotech.com

Avago, Avago Technologies, and the A logo are trademarks of Avago Technologies in the United States and other countries.
Data subject to change. Copyright © 2010 Avago Technologies Obsoletes AV00-0146EN
AV00-0171EN 01/05/10

AVAGO
TECHNOLOGIES